



PicoBlaze™

Frequency Generator for Spartan-3E Starter Kit

Ken Chapman
Xilinx Ltd
18th July 2006

*With special thanks to
Peter Alfke and Alireza Kaviani.*

Rev.1

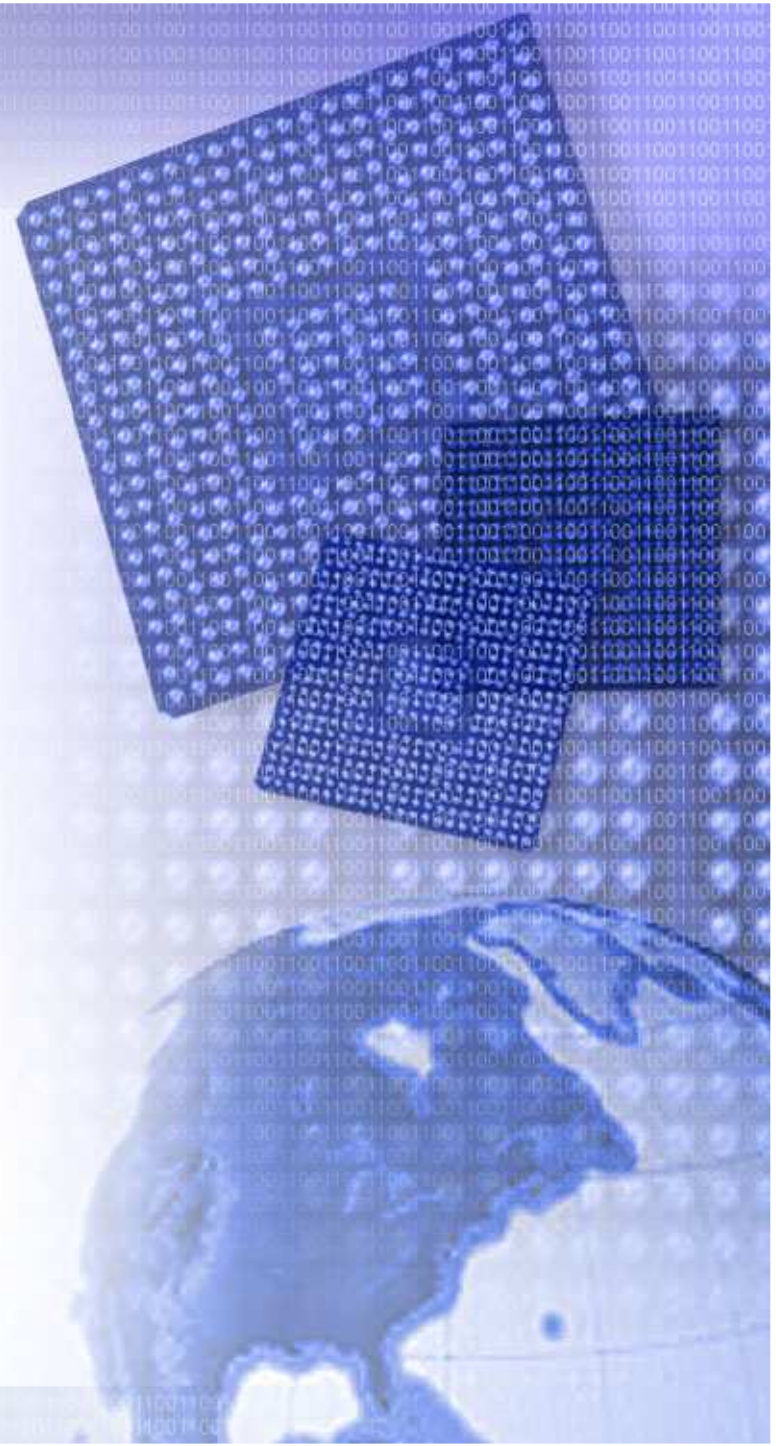

Limitations

Limited Warranty and Disclaimer. These designs are provided to you “as is”. Xilinx and its licensors make and you receive no warranties or conditions, express, implied, statutory or otherwise, and Xilinx specifically disclaims any implied warranties of merchantability, non-infringement, or fitness for a particular purpose. Xilinx does not warrant that the functions contained in these designs will meet your requirements, or that the operation of these designs will be uninterrupted or error free, or that defects in the Designs will be corrected. Furthermore, Xilinx does not warrant or make any representations regarding use or the results of the use of the designs in terms of correctness, accuracy, reliability, or otherwise.

Limitation of Liability. In no event will Xilinx or its licensors be liable for any loss of data, lost profits, cost or procurement of substitute goods or services, or for any special, incidental, consequential, or indirect damages arising from the use or operation of the designs or accompanying documentation, however caused and on any theory of liability. This limitation will apply even if Xilinx has been advised of the possibility of such damage. This limitation shall apply notwithstanding the failure of the essential purpose of any limited remedies herein.

This design module is **not** supported by general Xilinx Technical support as an official Xilinx Product. Please refer any issues initially to the provider of the module.

Any problems or items felt of value in the continued improvement of KCPSM3 or this reference design would be gratefully received by the author.

Ken Chapman
Senior Staff Engineer – Spartan Applications Specialist
email: chapman@xilinx.com

The author would also be pleased to hear from anyone using KCPSM3 with information about your application and PicoBlaze has been useful.



Design Overview

This design converts the Spartan-3E Starter Kit into a reasonably accurate frequency generator covering the nominal range 1Hz to 100MHz. The design allows you to attempt generation of higher frequencies to allow you to experiment with the maximum performance of the Spartan device on your board. The rotary control is used to edit the frequency displayed on the upper line of the LCD display and the corresponding frequency will then be output on the SMA connector (J17) as well as the stake pin J4-IO12. Internally to the device the frequency range is twice that provided externally (nominally up to 200MHz).

As well as providing the basic instructions to use the frequency counter, this document provides details of the Direct Digital Synthesis (DDS) techniques used in the design such that they can be transplanted into your own designs. PicoBlaze is used to provide the human interface and perform so high precision calculations which are passed to a simple but high performance (200MHz) frequency synthesizer formed from pure hardware and two Digital Clock Managers (DCMs). The lower line of the LCD display provides the information passed from PicoBlaze to the hardware which means that you can use this design with your board to determine the exact values required to implement a fixed frequency synthesizer without requiring PicoBlaze, the knob and LCD display. On this board the technique provides a convenient alternative to fitting a special oscillator in the IC16 socket and it may prove a cost effective solution for many real product applications too.

Load it now – it only takes 30 seconds!

It is recommended that you try this to become familiar with what the design does (operating instructions on the next page).

As well as the source design files, a compiled configuration bit file is provided which you can immediately download into the Spartan XC3S500E device on your board. To make this task really easy the first time, unzip all the files provided into a directory and then....

double click on

'install_frequency_generator.bat'.

Assuming you have the Xilinx software installed, your board connected with the USB cable and the board powered (don't forget the switch), then this should open a DOS window and run iMPACT in batch mode to configure the Spartan-3E with the design.

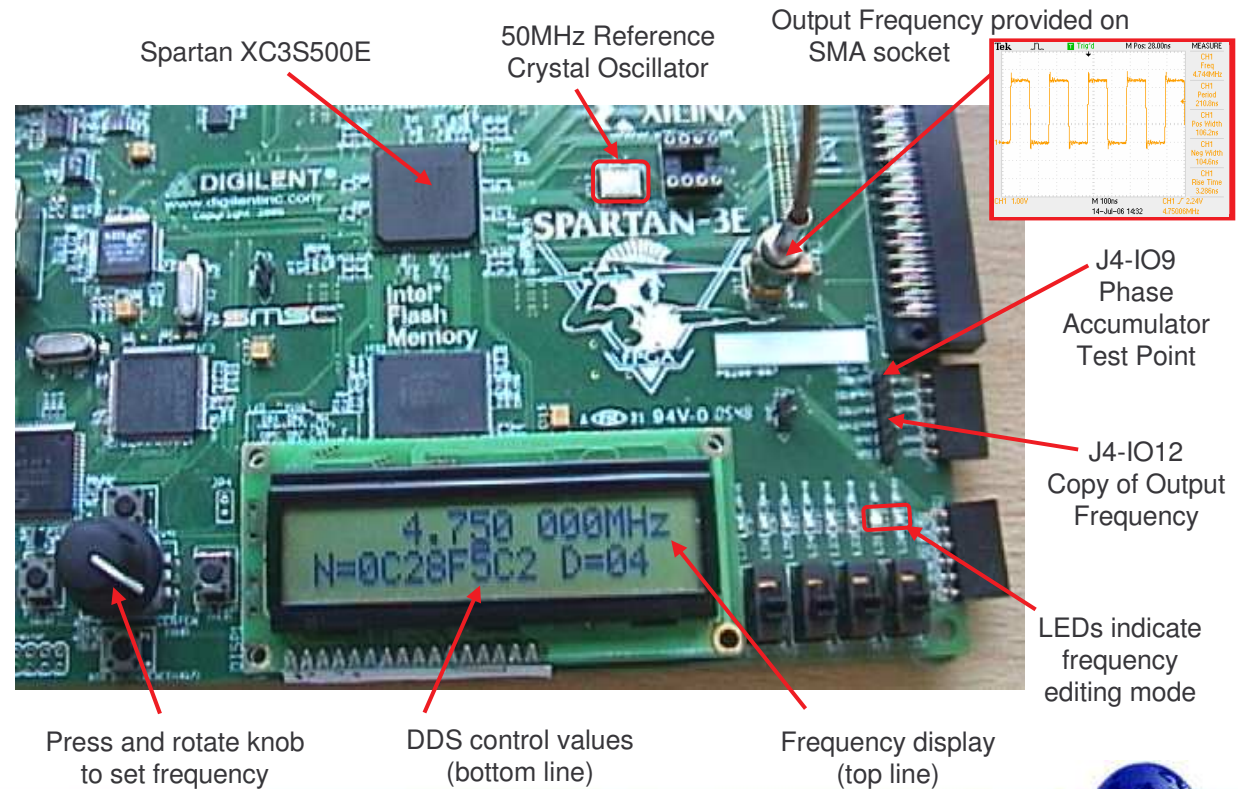

Operating Instructions



Output frequency provided on SMA connector (J17) and J4_IO12.

LEDs indicate the editing mode.

□ □ □ □ □ □ □ ■ = Edit cursor position mode

□ □ □ □ □ □ □ ■ □ = Edit digit value mode

Press and release knob to toggle between frequency editing modes

Edit cursor position mode

In this mode rotating the knob to the left or right will cause the display cursor to move in the corresponding direction on the upper line of the display. Use this mode to position the cursor below the digit you wish to adjust and then press and release the knob to change mode. The cursor automatically skips past the decimal point and space separator and hits 'end stops' if you over rotate the knob.

The cursor can be moved into the 10MHz and 100MHz digit positions but these positions are blanked when zero.

The cursor is the small black line under the digit in the top line.



Edit digit value mode

In this mode rotating the knob to the left or right will decrement or increment the value of the digit located at the cursor position. The controller will automatically borrow from, or carry to, the more significant digits to the left of the digit being adjusted. Every adjustment will immediately result in the corresponding frequency change at the output which is also reflected by the changes to the computed DDS control values on the lower line of the display. Press and release the knob to revert to cursor position mode when complete.

PicoBlaze Design Size

The images and statistics on this page show that the design occupies just 172 slices, 1 BRAM and 2 DCMs. This is only 3.7% of the slices available in an XC3S500E device. More significantly, this slice count can be reduced to less than 32 when implementing a fixed frequency version.

MAP report

Number of occupied Slices:	172 out of	4,656	3%
Number of Block RAMs:	1 out of	20	5%
DCMs:	2 out of	4	50%
Total equivalent gate count for design: 91,537			

PicoBlaze makes extensive use of the distributed memory features of the Spartan-3E device leading to very high design efficiency. If this design was replicated to fill the XC3S500E device, it would represent the equivalent of over 1.5 million gates. Not bad for a device even marketing claims to be 500 thousand gates ☺

FPGA Editor view

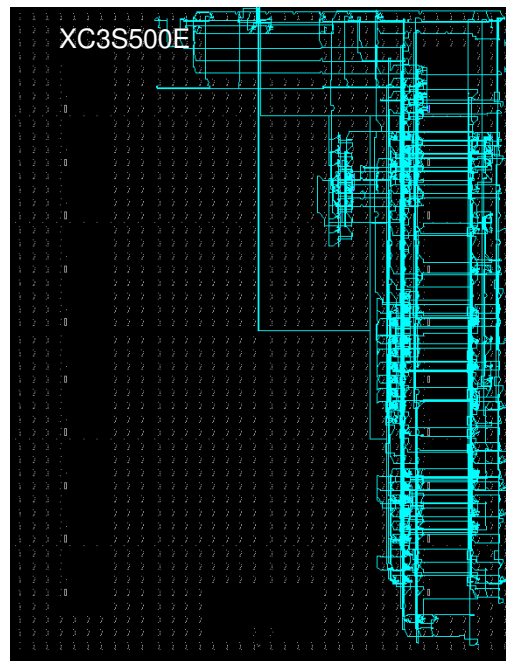

Floorplanner view



Design Files

The source files provided for the reference design are.....

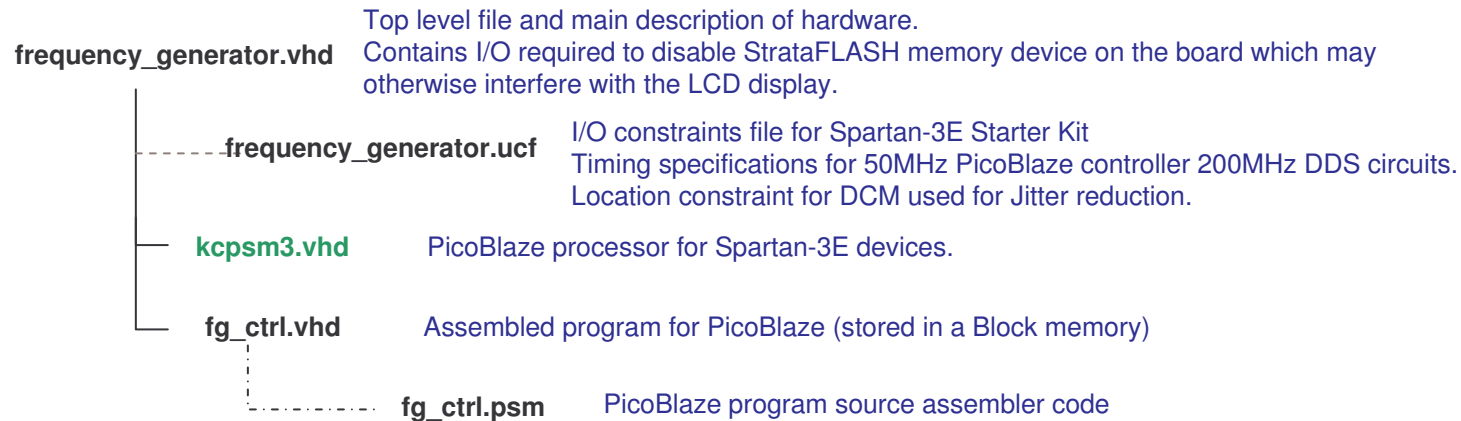

This design contains an otherwise undocumented and unspecified mode of operation for a DCM. Before this design can be processed a special BITGEN option needs to be set. Please read the notes provided on page 13 as well as those contained in 'frequency_generator.vhd' for details of this special requirement.

Note: The file shown in **green** is not included with the reference design as it is provided with PicoBlaze download. Please visit the PicoBlaze Web site for your free copy of PicoBlaze, assembler, JTAG_loader and documentation.

www.xilinx.com/picoblaze

Hint – The JTAG_Loader utility supplied with PicoBlaze has been included in this design. This enables the new programs to be written for PicoBlaze using the configuration file provided.

Hint – You do not need PicoBlaze if you use this design as the basis for implementing a fixed frequency module. However, I'm sure you will want PicoBlaze for other parts of your design now that you have seen what it is capable of doing ☺.



Direct Digital Synthesis (DDS) Circuit Diagram

The phase accumulator is a standard 32-bit accumulator operating at 200MHz. This accumulator is really the heart of the DDS as it is the most significant bit of the accumulator that produces the variable frequency being synthesized. The remaining circuits only multiply, divide and clean this synthesized frequency or are involved with selecting and generating the DDS control words.

The frequency of the most significant bit is defined by the 32-bit value applied to the input of the accumulator. This value is shown as 'N' on the LCD display and is applied to the bus 'dds_control_word' in the circuit. The value of N is computed in such a way that the synthesized frequency is nominally in the range 6.25MHz to 12.5MHz so that it is always a suitable input to the second DCM.



$$F_{MSB} = \frac{N \times 200MHz}{2^{32}}$$

In this example N=204010946 decimal so the output from the phase accumulator is ~9.5MHz (a period of approximately 105ns). That means that the accumulator synthesizes one output cycle for approximately 21 cycles of the 200MHz clock from which the accumulator runs.

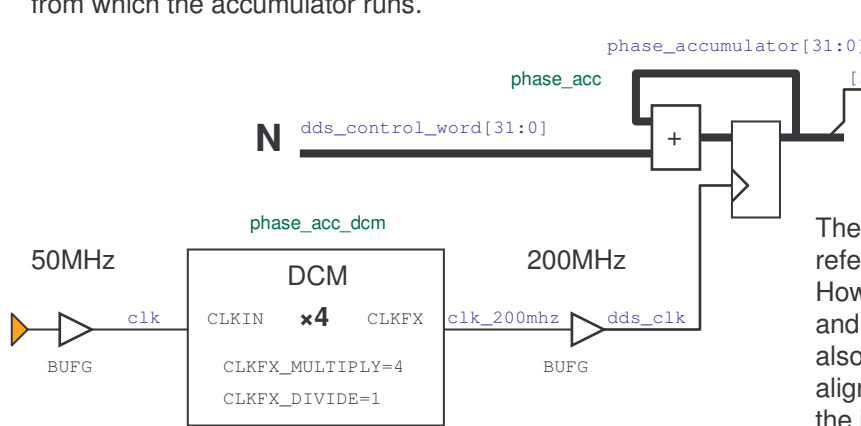

The first DCM is used to multiply the 50MHz clock by a factor of 4 and form a 200MHz clock. This gives the phase accumulator a timing resolution of 5ns.

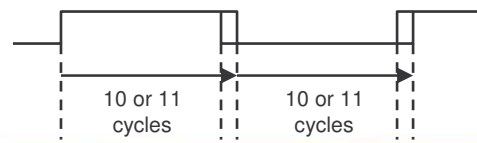

The second DCM is used in a 'frequency aligned mode'. At the time of writing this reference design, this mode is not an officially documented or supported feature. However, it is hoped that this reference design will enable you to see this mode in action and evaluate it for yourself. In this mode, the DCM not only multiplies the input clock, but also has the effect of reducing cycle to cycle jitter. This is because the normal phase alignment mode of the DCM has been disabled and the DCM is tracking the average of the input frequency instead.

In the example, the input to the DCM will have 5ns of cycle to cycle jitter as the square wave is formed from 21 cycles of 200MHz. The DCM will generate ~153MHz square wave with <300ps of jitter.

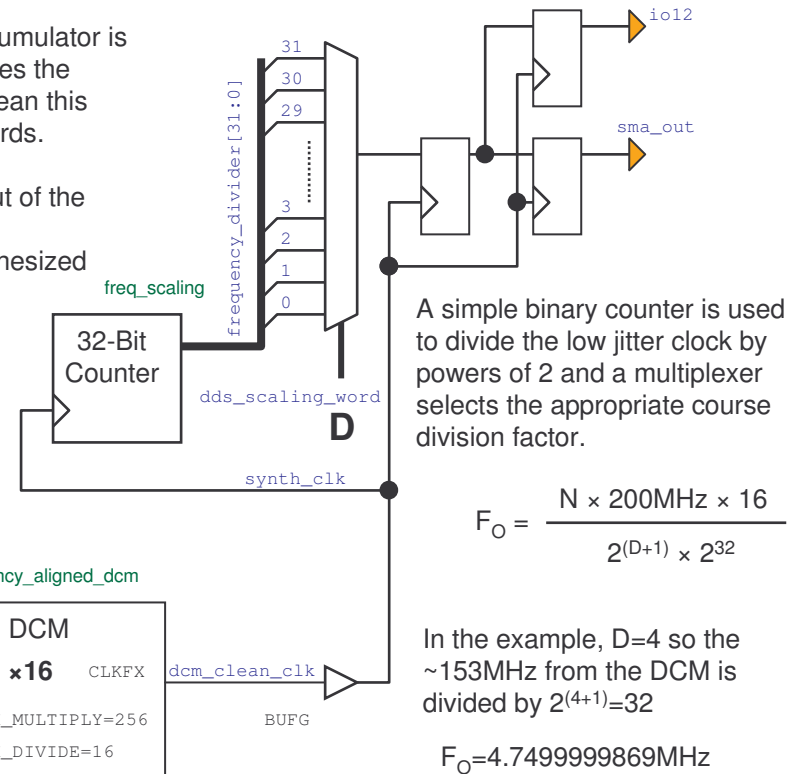

A simple binary counter is used to divide the low jitter clock by powers of 2 and a multiplexer selects the appropriate course division factor.

$$F_O = \frac{N \times 200MHz \times 16}{2^{(D+1)} \times 2^{32}}$$

In the example, D=4 so the ~153MHz from the DCM is divided by $2^{(4+1)}=32$

$$F_O = 4.7499999869MHz$$



PicoBlaze Circuit Diagram

PicoBlaze provides the user interface and performs the calculations required to generate the 32-bit DDS control word 'N' and 5-bit DDS scaling word 'D'.

Hint – The 'fg_ctrl.psm' file contains significant comments to explain the operations and calculations that the PicoBlaze program is performing to generate 'N' and 'D' from the BCD value displayed on the LCD.

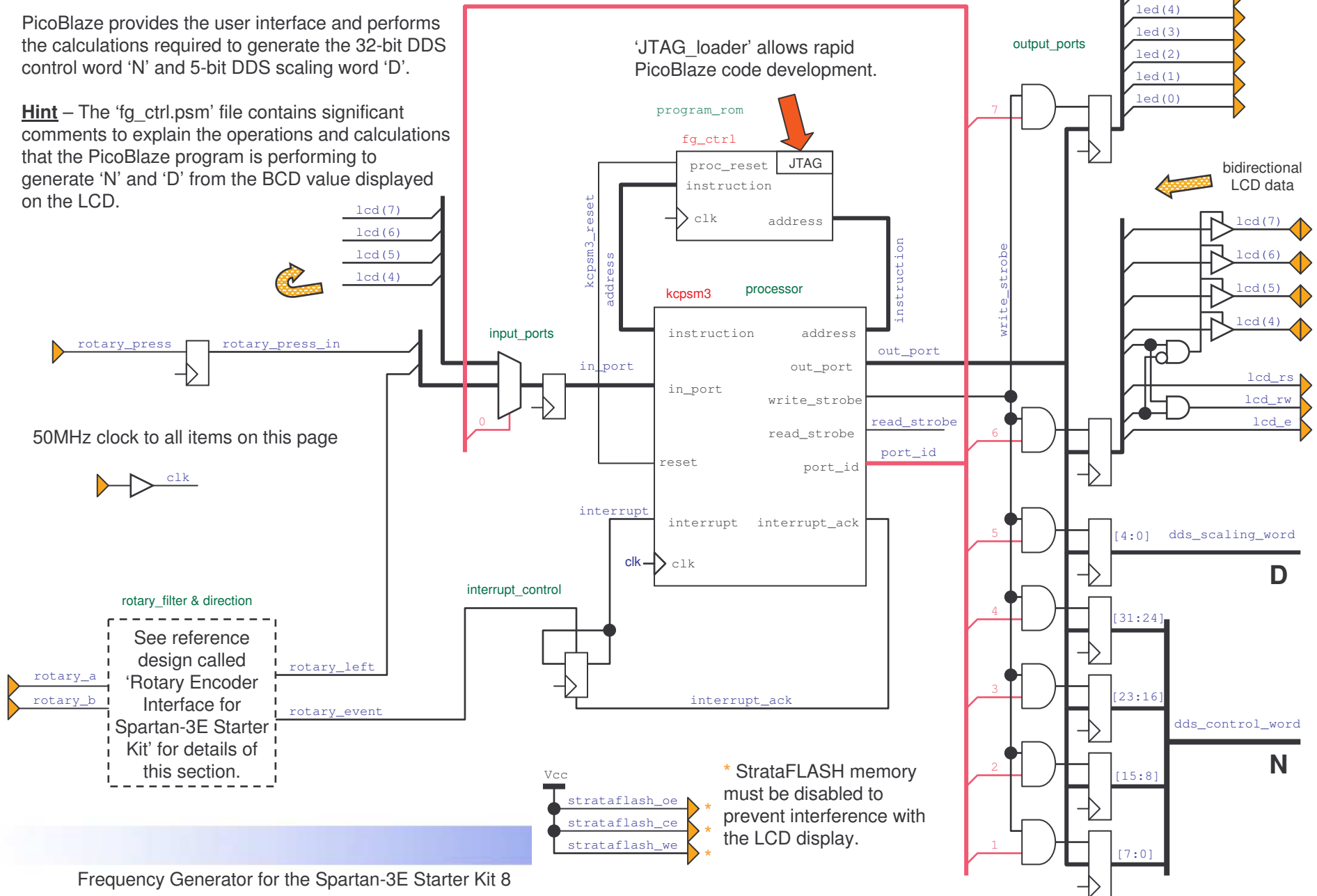

Phase Accumulator Waveforms

The following waveforms were obtained by monitoring the output of the phase accumulator presented on stake pin 'J4-IO9'. In each case the digital storage oscilloscope was set to infinite persistence in order capture any fluctuations over time and therefore observe the 'envelope' of operation.

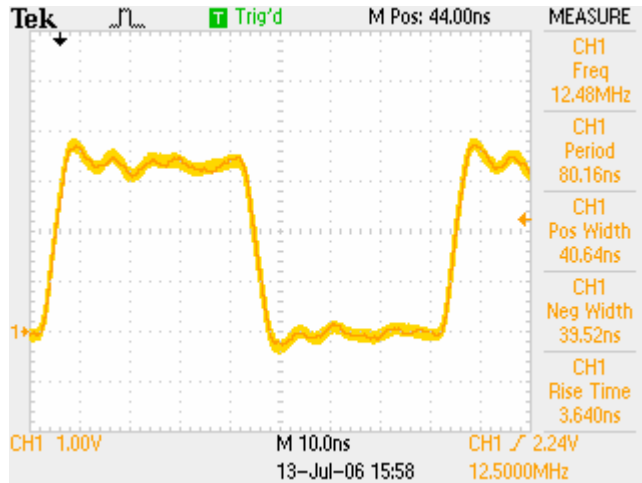

This waveform shows a pretty clean 12.5MHz square wave. The reason the waveform is so clean is because 12.5MHz is a perfect division of the 200MHz clock used by the phase accumulator and it means that the synthesized waveform is always formed of 16 clock periods of the 200mHz clock with 8 Low and 8 High.

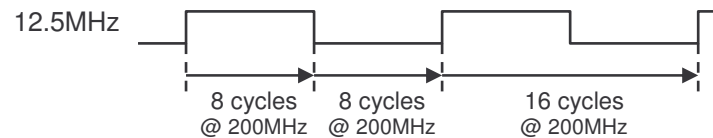

Note that to force this frequency at the phase accumulator I actually dialled in a frequency of 100MHz on to the LCD display such that N=10000000 hex.

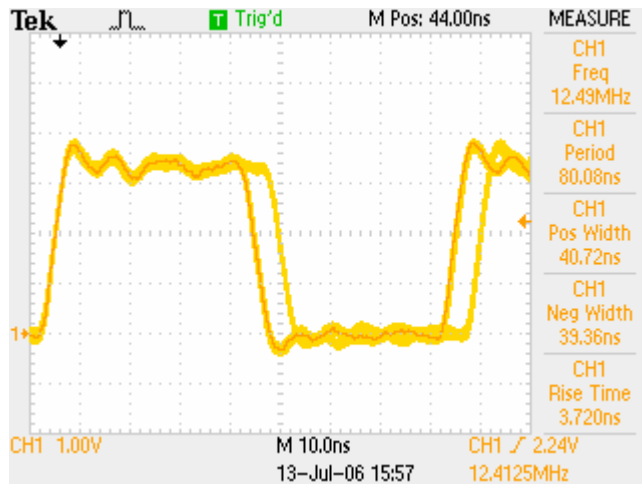

This waveform shows what happens when you try to synthesize a 12.4125MHz clock using the phase accumulator. There is clearly 5ns of cycle to cycle jitter in this situation because each output cycle really should be formed of ~16.113 periods of the 200MHz clock which is impossible. Therefore what the phase accumulator is doing is to provide the correct average frequency by making some cycles of 16 periods and then make approximately 1 in every 9 cycles have 17 periods; a mix of 12.5MHz and 11.767MHz waveforms.

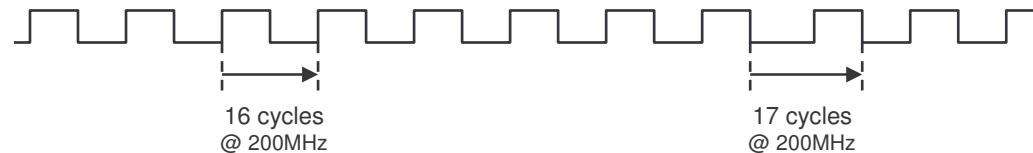

Note that to force this frequency at the phase accumulator I actually dialled in a frequency of 99.3MHz on to the LCD display such that N=0FE353F7 hex

5ns of cycle to cycle jitter is often acceptable when synthesizing lower frequencies especially if the waveform is only used as a digital clock for control and timing of slower events. However, for higher frequencies such jitter becomes unacceptable (i.e. at 100MHz the cycle period is only 10ns).

Phase Accumulator Spectrum

An alternative way to observe the quality of the waveforms synthesised by the phase accumulator is to look at the frequency spectrum. I was lucky enough to have a 2048-point FFT feature on my oscilloscope which allows some simple observations to be made. Once again I have set the display to infinite persistence in order capture the spectrum over a long period of time (>15 seconds). I suggest that you do not look for exact values, but compare the plots which have been captured using the same scales in each case. On the left are plots that show the spectrum up to 50MHz and on the right the plots show are zoomed in to show $\pm 5\text{MHz}$ centred on 12.5MHz.

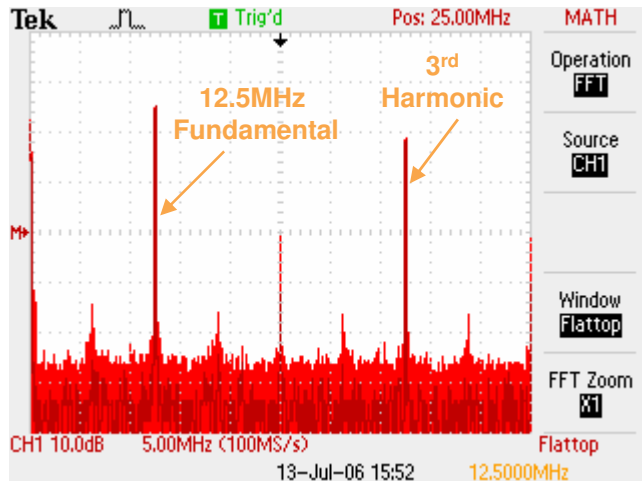

As we know the 12.5MHz signal is nominally clean in terms of the synthesis process and this is reflected by a distinct 12.5MHz component which is >45dB above the noise floor. The zoomed plot shows how the fundamental covers only a narrow bandwidth keeping in mind that the resolution of the FFT is only $\sim 50\text{KHz}$.

Note the third harmonic of a square wave is also very distinct at 37.5MHz and is even close to being the theoretical 9.54dB down from the fundamental (1/3 amplitude).

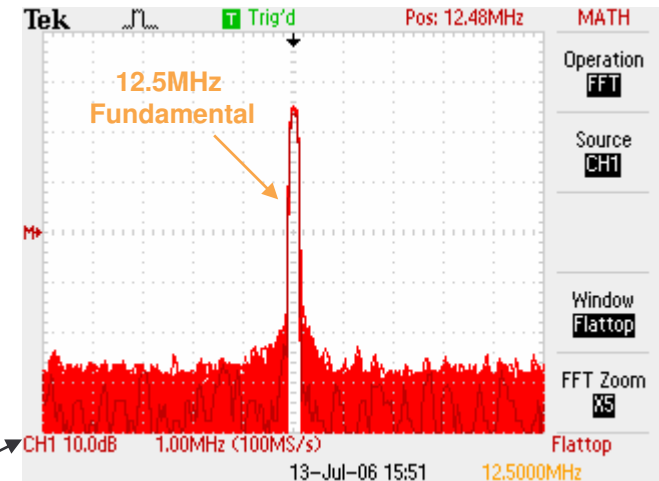

5MHz/division
10dB/division

1MHz/division
10dB/division

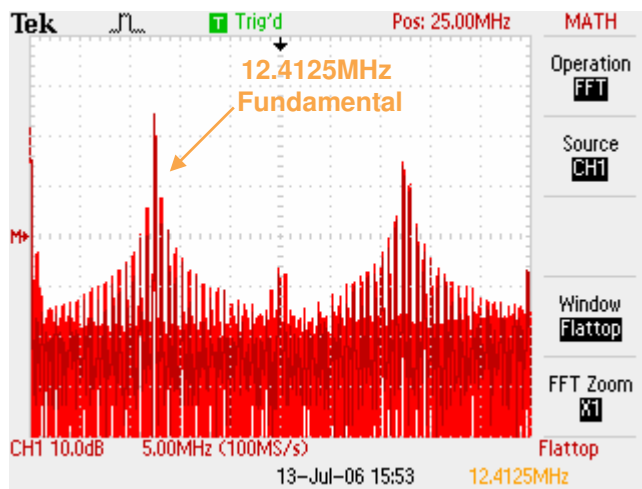

When we move to the less than perfect 12.4125MHz waveform the effects of that 5ns of cycle jitter and jumping between 12.5MHz and 11.76MHz waveforms is obviously having an impact on the spectrum. Although the fundamental frequency component is good, if a little wider in bandwidth, there are significant modulation effects leading to a family of spectral components and raised noise floor. Hint – $12.5\text{MHz} - 11.76\text{MHz} = 0.74\text{MHz}$

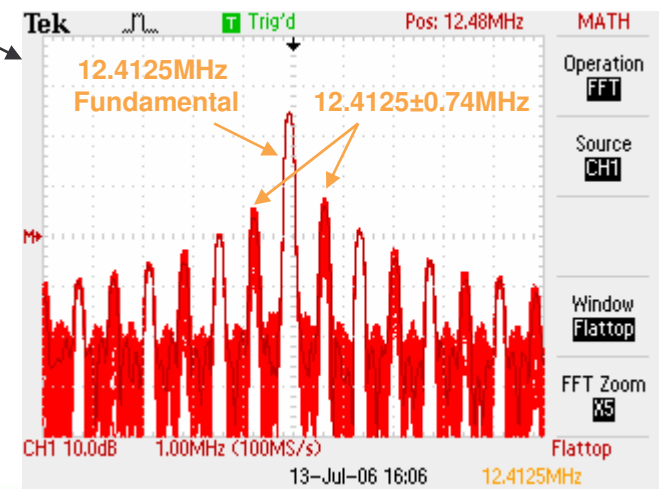

Final Output Waveforms

These waveforms were obtained from stake pin 'J4-IO12' and reflect the final output of the frequency generator. Once again the digital storage oscilloscope was set to infinite persistence in order capture any fluctuations over time and therefore observe the 'envelope' of operation.

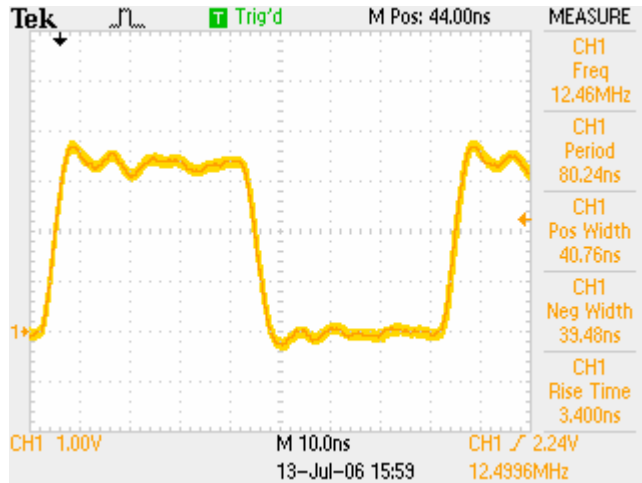

In these cases the frequency shown on the LCD display directly corresponds to the frequency provided at the output. However it is useful to understand what the phase accumulator is generating to appreciate if the second DCM in 'frequency aligned mode' is helping.

For this 12.5MHz waveform N=08000000 hex and D=02 hex. So in fact the phase accumulator is synthesizing 6.25MHz. This is again a perfect division of the 200MHz clock and means that the synthesized waveform is always formed of 32 clock periods with 16 Low and 16 High. There is therefore no obvious cycle jitter introduced and therefore it is not surprising that the final output ($6.25\text{MHz} \times 16 / 2^{(2+1)} = 12.5\text{MHz}$) is also nice and clean.

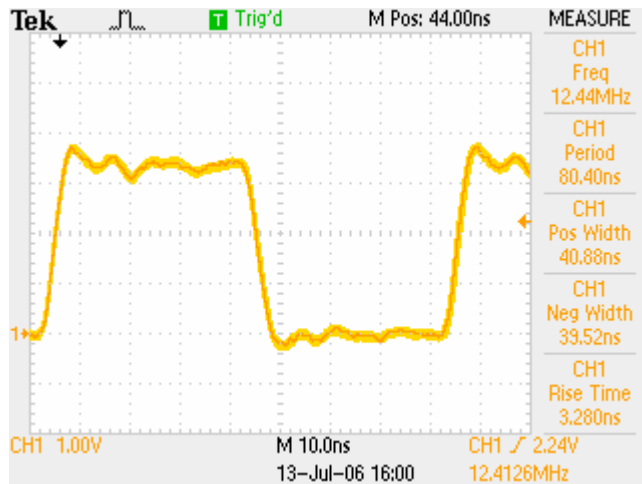

You may have to look closely to notice that this second plot really is 12.4125MHz. It is immediately clear that there is no obvious cycle to cycle jitter present. To confirm that this isn't just a coincidence, we must again consider what the phase accumulator is doing at the same time.

With 12.4125MHz set, N=0FE353F7 hex and D=03 hex. So in fact the phase accumulator is actually synthesizing 12.4125MHz as well. More significantly, it means that the phase accumulator is generating exactly the same waveform as we observed previously on page 9 in which there was 5ns of cycle to cycle jitter present (see right).

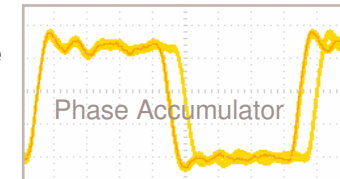

The final output ($12.1425\text{MHz} \times 16 / 2^{(3+1)} = 12.125\text{MHz}$) shows that the frequency aligned mode of the DCM is tracking the average frequency of the input waveform and totally ignoring the phase of the input waveform resulting in a very low cycle to cycle jitter. In fact the DCM is only using the frequency information from the input waveform and the output cycle jitter is totally independent of the input cycle jitter.

Hint – When using a DCM in frequency aligned mode, you must accept that it does NOT maintain phase lock as it does in all other 'normal' modes. More significantly the output frequency is the average of the input frequency which means there will often be a slight difference as it *tracks* the input.

Final Output Spectrum

Observing the frequency spectrum of the final output reveals that you can not get something for nothing and helps us to understand when the frequency aligned mode should and should not be used. I have used the infinite persistence display again and this time it was even more useful to do so. As before, plots on the left cover up to 50MHz and on plots on the right show $\pm 5\text{MHz}$ centred on 12.5MHz.

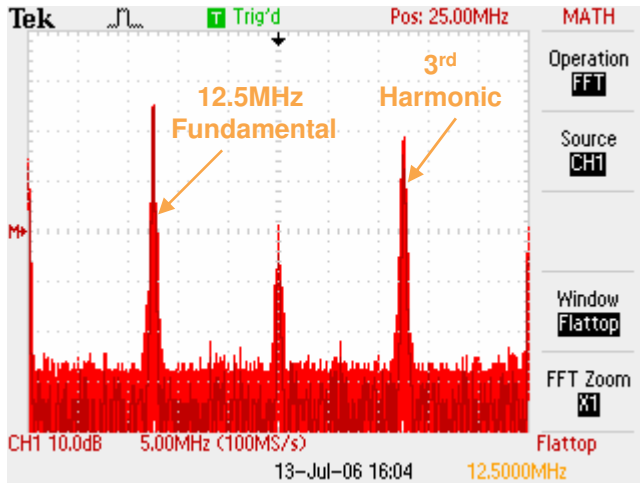

These plots show that the 12.5MHz signal is actually not as good as that generated directly at the output of the phase accumulator. Although clearly centred at 12.5MHz the spectrum shows that there is an increased bandwidth. This reflects that the DCM is tracking the input frequency even though it doesn't really need to do anything. It is rather like balancing on a wall; we know the wall isn't moving but we still wobble a bit to stay balanced because we are unable to freeze completely due to other influences on us and the need to breath etc!

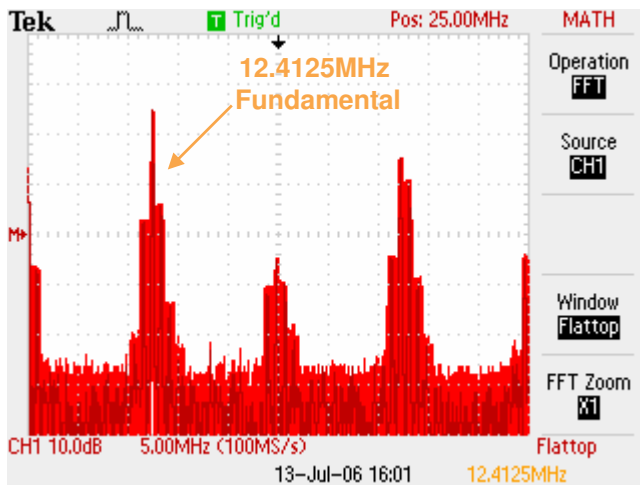
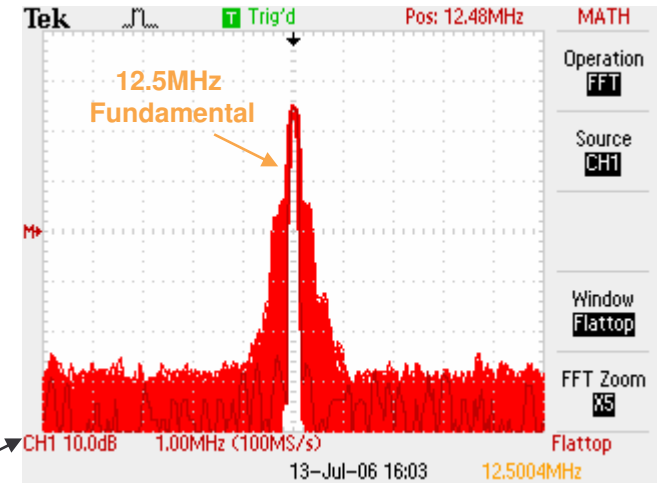

The full spectrum of the 12.4125MHz case shows how the previous 'family of spectral components' associated with the 5ns of cycle jitter have been removed and that the noise floor has been returned to normal levels. The zoomed plot now shows a fundamental with what looks like modulation sidebands rather than fixed spectral components at $\pm 0.74\text{MHz}$. This again reflects average frequency tracking as well as the removal of the 5ns cycle jitter. Note that an agile frequency component has a lower energy (W/Hz) than a static component.

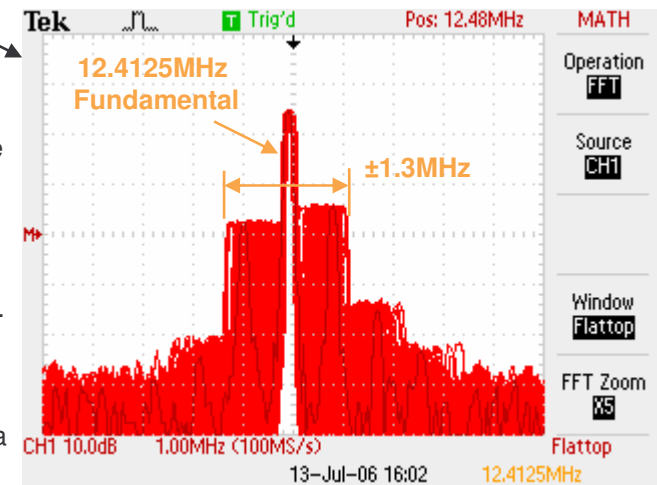

Hint – If you can synthesize a perfect waveform with a phase accumulator or other direct clock division circuit then it does NOT make sense to use a DCM in frequency aligned mode. In all non integer division cases the DCM will dramatically help jitter performance but some frequency 'tracking' must be accepted.

Setting DCM Frequency Aligned Mode

To set the DCM into the frequency aligned mode of operation a special option must be used during configuration file generation. This can be set in the ISE tools as shown in these screen shots from an ISE v8.1i project for this reference design.

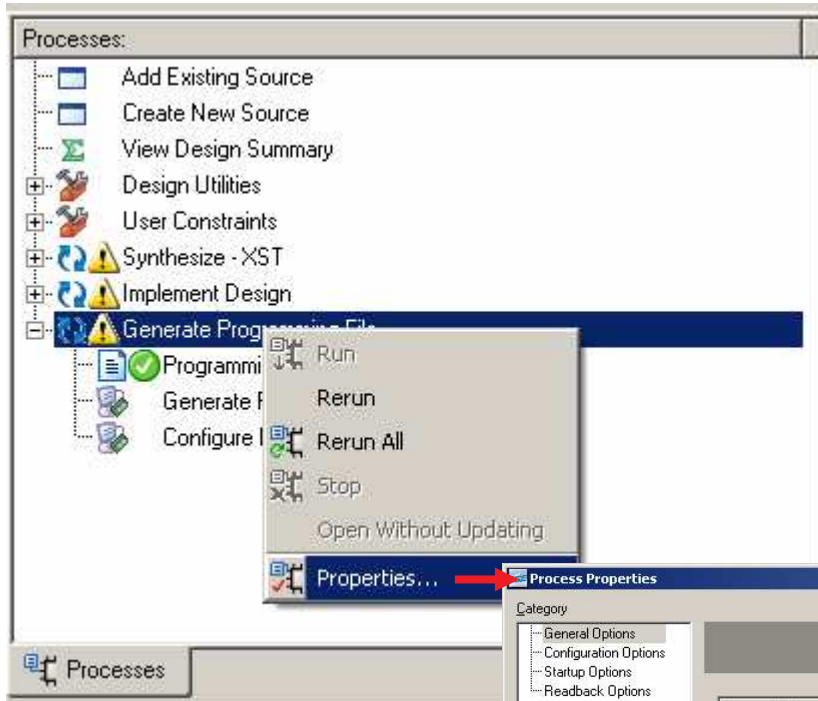

1) In the 'Processes' window select 'Generate Programming File'. Then right click and select 'Properties' to open the 'Process Properties' box.

2) The 'Process Properties' box should open with the 'General Options' being shown (otherwise select 'General Options' on the left). Move to the line 'Other Bitgen Command Line Options' and enter the text string shown below.

Hint – You may need to set 'Property display level' to 'Advanced' and scroll down to see this line.

3) Select 'Apply' and then use 'OK' to exit the box.

Hint – Reopen the box and confirm the option really was set correctly.

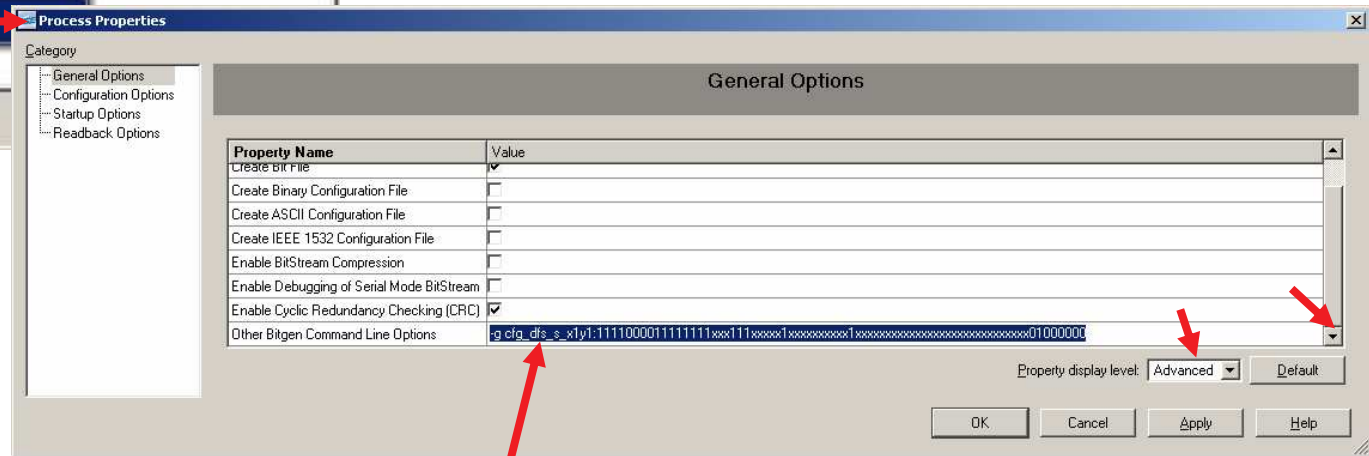

Hint – The format of this special DCM option are described in some detail in the 'frequency_generator.vhd' file from which you can also copy and paste to avoid typing errors!

-g cfg_dfs_s_x1y1:1111000011111111xxx111xxxxx1xxxxxxxxxxx1xxxxxxxxxxxxxxxxxxxxxxxxxxxxxxxx01000000



Exercises, Experiments and Suggestions

Here are some exercises, experiments and suggestions for you to consider based on this reference design. Although several are specific to the Spartan-3E Starter Kit, most are portable to your own boards and designs where I hope you will find the design concept useful.

Turn it off!

Probably the best way to convince yourself that the frequency aligned mode of the DCM is really doing something special is to turn it off (remove the special BITGEN option) and then look at the output waveform on an oscilloscope particularly at frequencies >50MHz.

How fast is yours?

The PicoBlaze controller does not limit the upper frequency that you can enter to see how high the frequency is that your board can generate.

Hint 1 – Although the display supports up to 999MHz, the largest valid value you can enter is 212.499999MHz because this sets N=0FFFFFFEA.

Hint 2 – The output from the second DCM is always divided by at least 2 before it reaches the output pin, so internally a clock can be faster.

Hint 3 – As you increase the frequency you will reach the limit of I/O performance. Experiment with increasing output drive strengths and FAST slew rates.

Save Oscillators and Save \$

This reference design could be the way to save money by replacing a set of different crystal oscillators required to support multiple standards etc. This design together with the board allows you to directly try the output with your own products and see if it works for you. The plots shown in this document clearly show that the final output has very low cycle to cycle jitter compared with the output from a phase accumulator DDS circuit. However, it is also shown that the output still has some additional frequency components as it tracks the average frequency. In some applications this will have no effect whilst others may find it an issue. Some applications can actually benefit from the partial spread spectrum effect (i.e. reduced EMC).

Fixed Frequency Modules

If you know which frequencies you require, then reduce the design to a phase accumulator driven by a constant 'N', the DCMs and a fixed counter divider (no multiplexer).

Hint – If you still operate the phase accumulator at 200MHz, then use the supplied design on the board to calculate your 'N' and 'D' values for you.

Hint – Remember to share the 200MHz fast clock between several phase accumulators to save DCMs.

Accurate Measurements

If you have access to superior measurement equipment, then measure the frequency generator output for yourself and observe the tracking nature of the output. Be careful not to confuse I/O and PCB effects with what you are attempting to measure using such good equipment.

Simple Frequency Measurements using the Spartan-3E Starter Kit

Create a fixed frequency version of the design for a frequency of your choice. Then insert that module into the reference design called 'PicoBlaze Frequency Counter for the Spartan-3E Starter Kit Board' in place of one of the existing sources so that you can observe the output frequency.

Hint – The output frequency should be correct, but you should be observing a variation above and below as the DCM tracks the average frequency value.

Design Throttling

This term is given to the concept of changing the frequency depending on the demands of an application over time. This is a way to save power since power consumption is directly proportional to operating frequency. The frequency aligned mode allows you to switch between frequencies without causing glitches and you can prove this with the design provided.

Hint – Increasing 'CCount' (read notes in 'frequency_generator.vhd') will provide very smooth but relatively slow rates of change in frequency.

