



3D Stereoscopic Vision

제갈량 **Cory Klein**

李立巨 **William Lee**

朴才旻 **Lorenzo Swank**

Motivation



Nvidia 3D Vision Glasses



**ANAGLYPH STEREO
(1 FRAME)**



**SHUTTERED STEREO
(MULTIPLE FRAMES)**

Flaws

- * Hardware Requirements
 - * High-end NVidia cards only!
 - * Glasses are expensive.
 - * 120 HZ LCD or better.
- * Software Requirements
 - * DirectX 10 games only.
 - * Windows Vista
 - * Windows 7



Solutions

- * Hardware
 - * Support any video card.
 - * Build wired glasses.
 - * Support any LCD.
- * Software
 - * Support OpenGL
 - * Windows, Mac, Linux, Playstation 3, iPhone

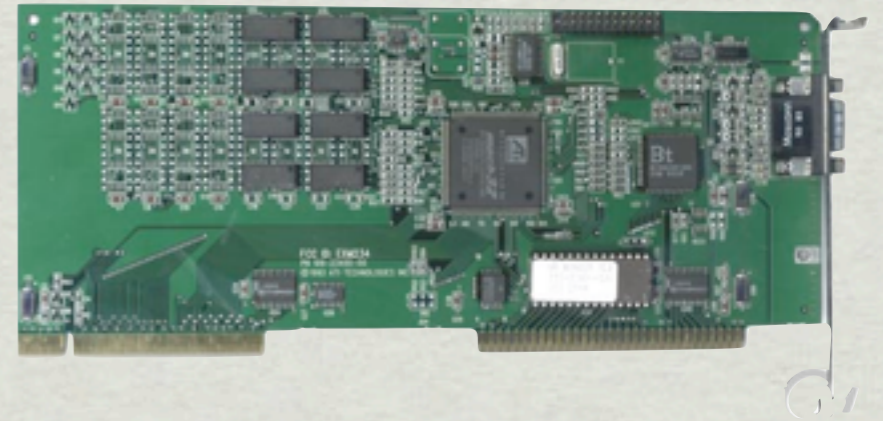

Improvements

- * Developing a solid interface for stereo vision with OpenGL
- * Demonstrated using our own custom ray tracer.



Implementation

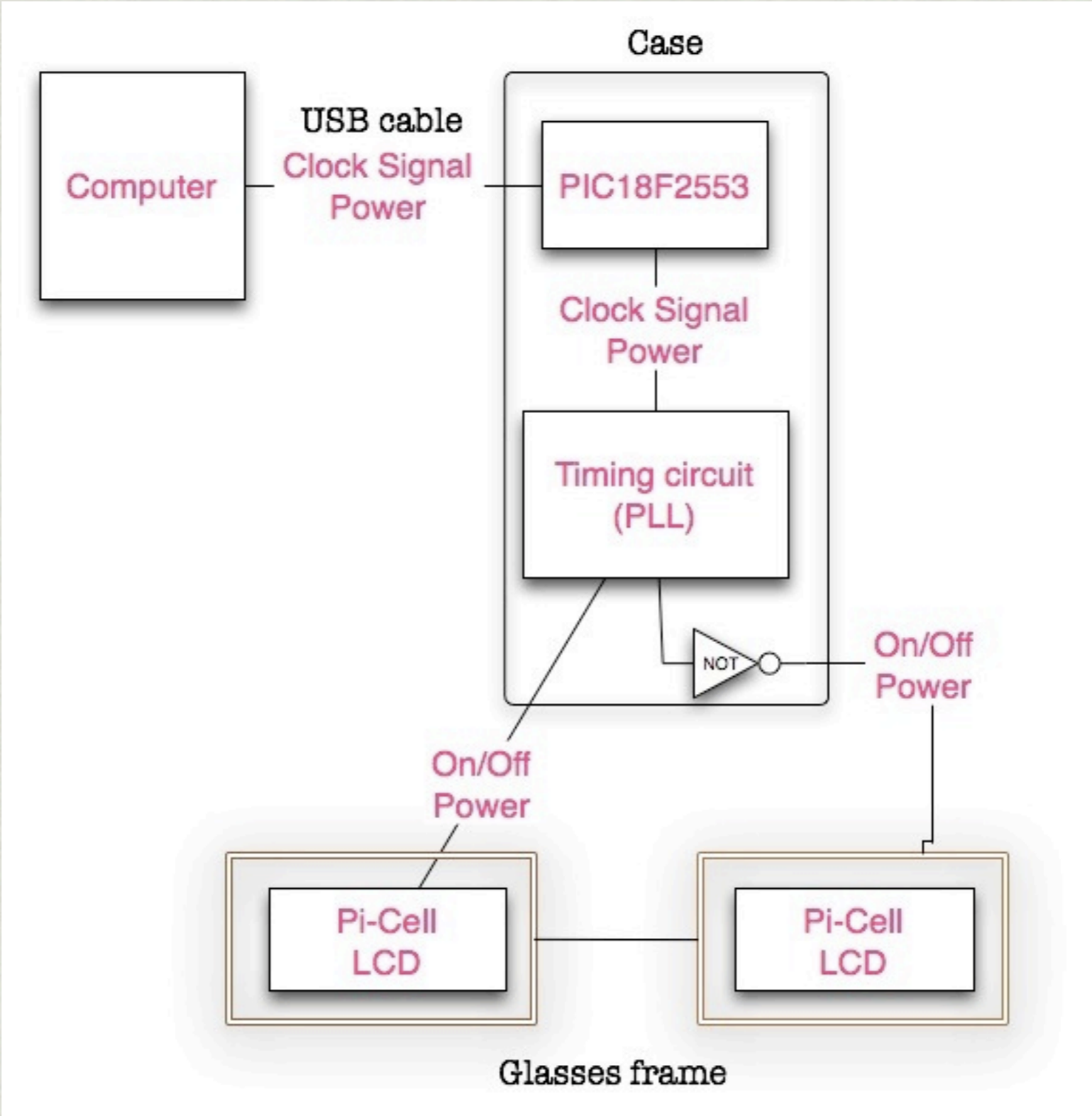

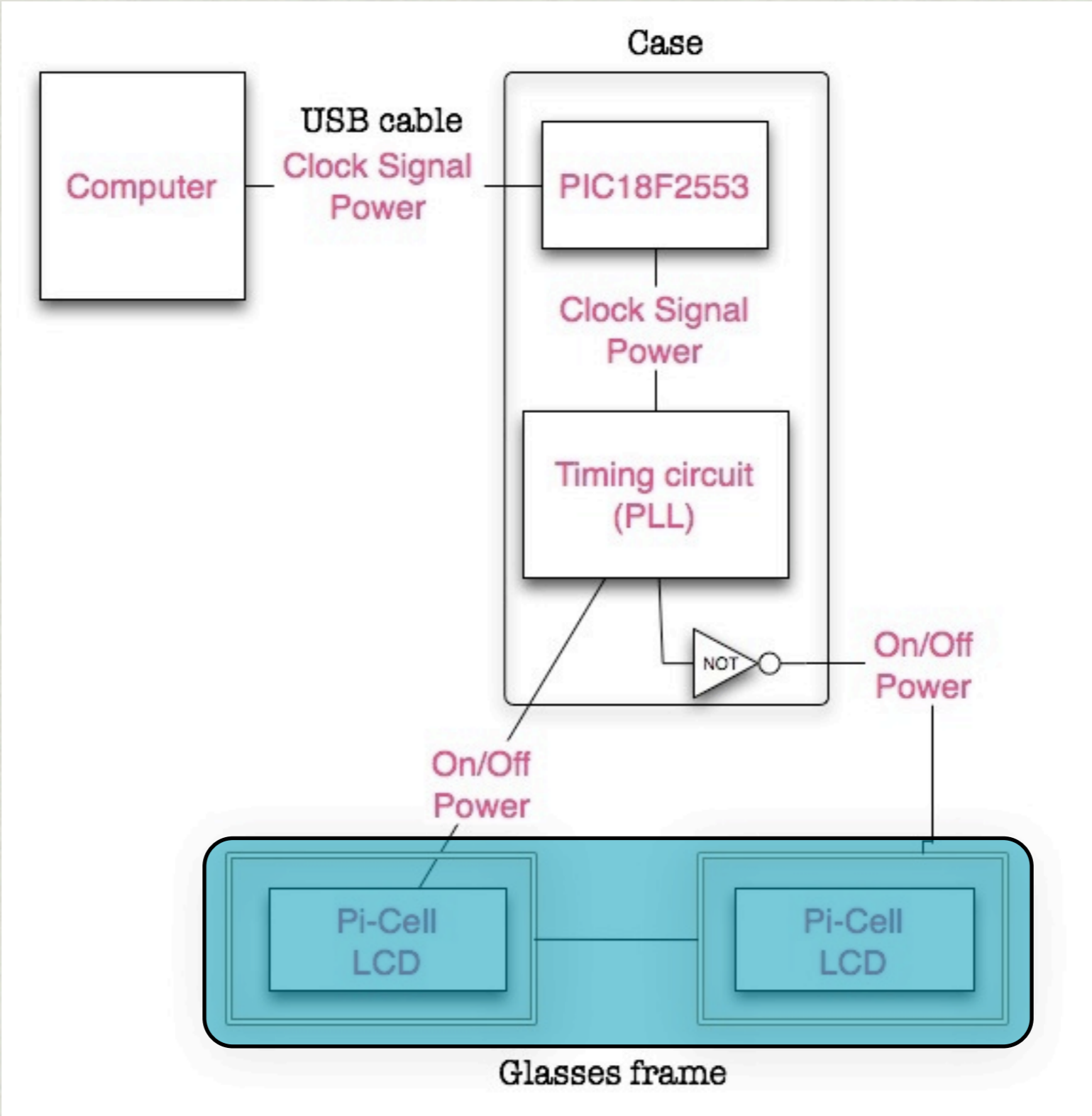

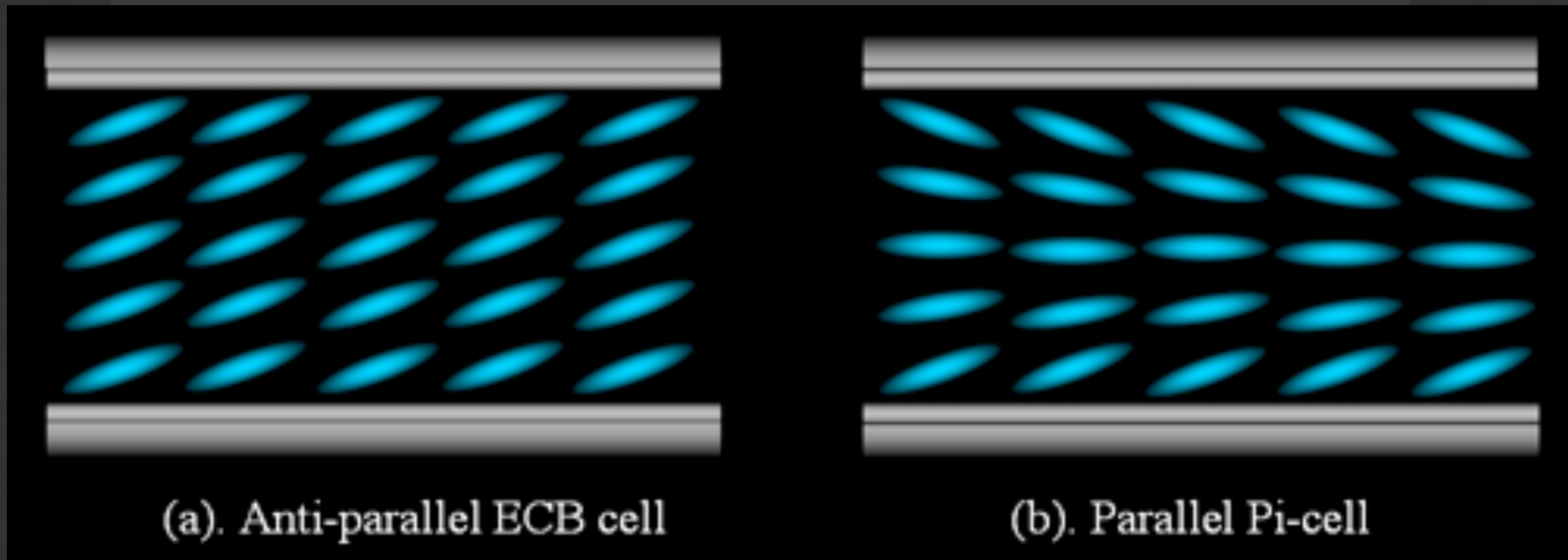

Timing circuit
(PLL)

On/Off
Power

Pi Cell, Transmittance vs. Voltage

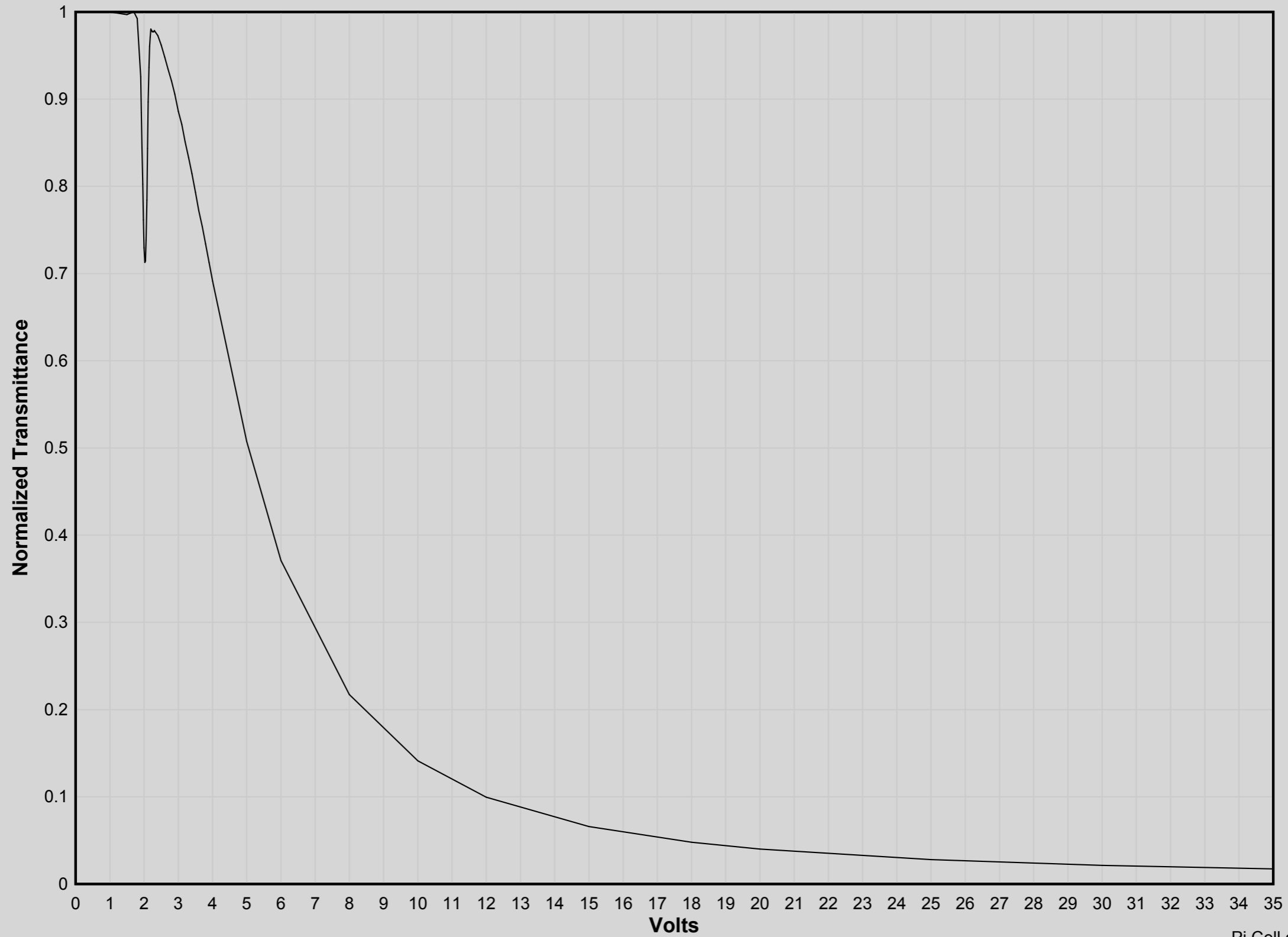

Pi Cell.grf

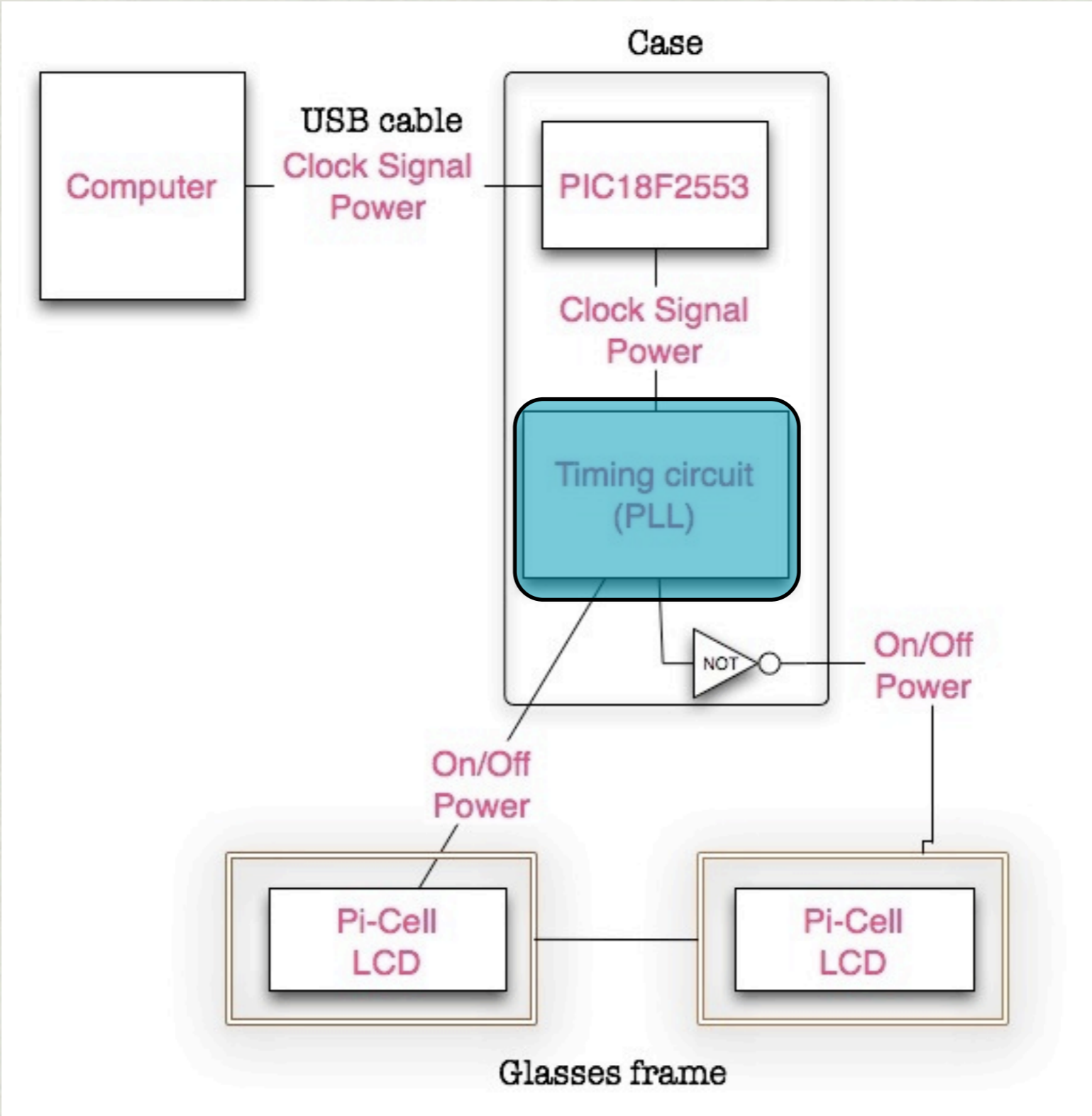

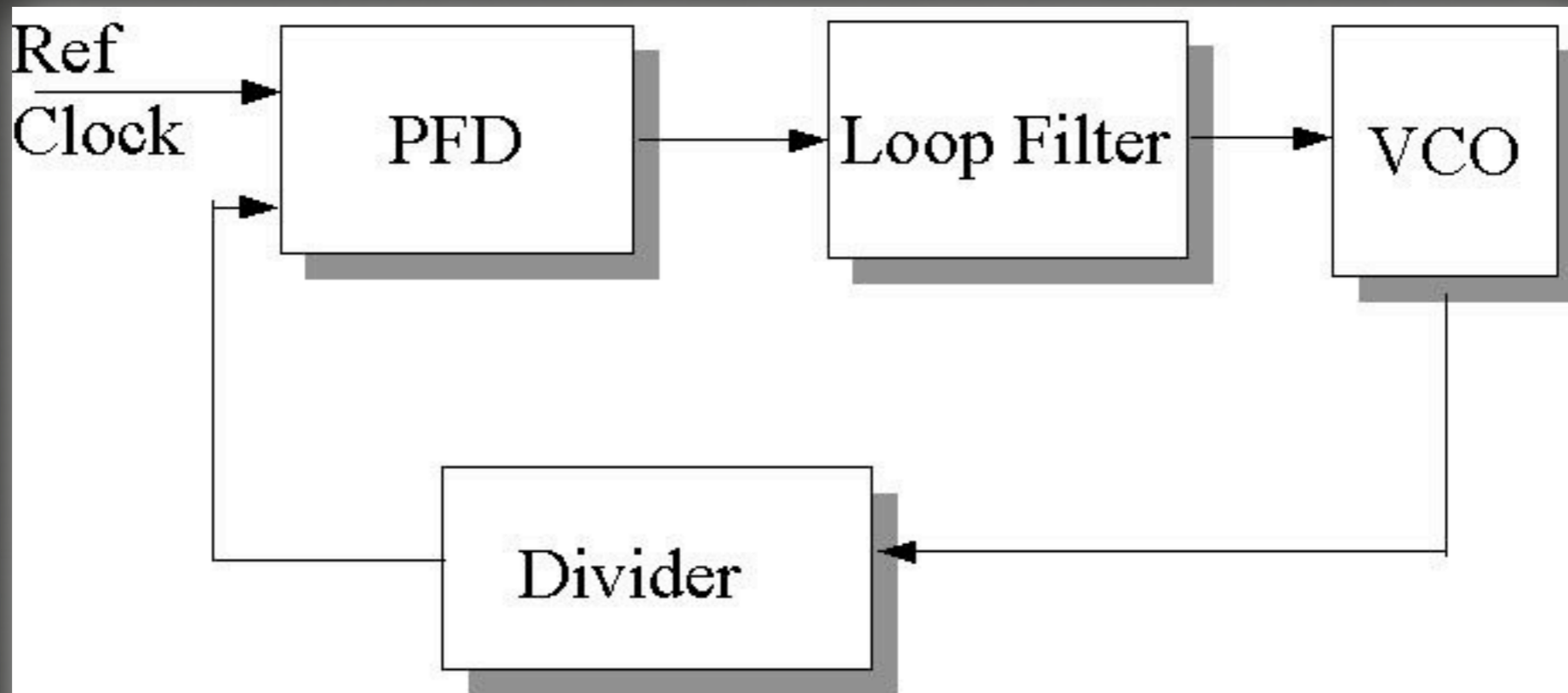

PLL Block Diagram

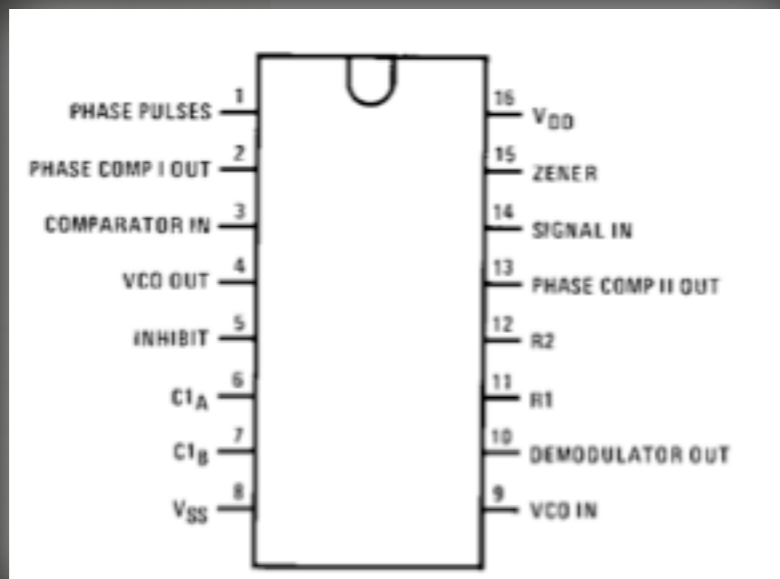

Features

- Wide supply voltage range: 3.0V to 18V
- Low dynamic power consumption: 70 μ W (typ.) at $f_o = 10$ kHz, $V_{DD} = 5$ V
- VCO frequency: 1.3 MHz (typ.) at $V_{DD} = 10$ V
- Low frequency drift: 0.06%/°C at $V_{DD} = 10$ V with temperature
- High VCO linearity: 1% (typ.)

On/Off Power

-Cell CD

Glasses frame

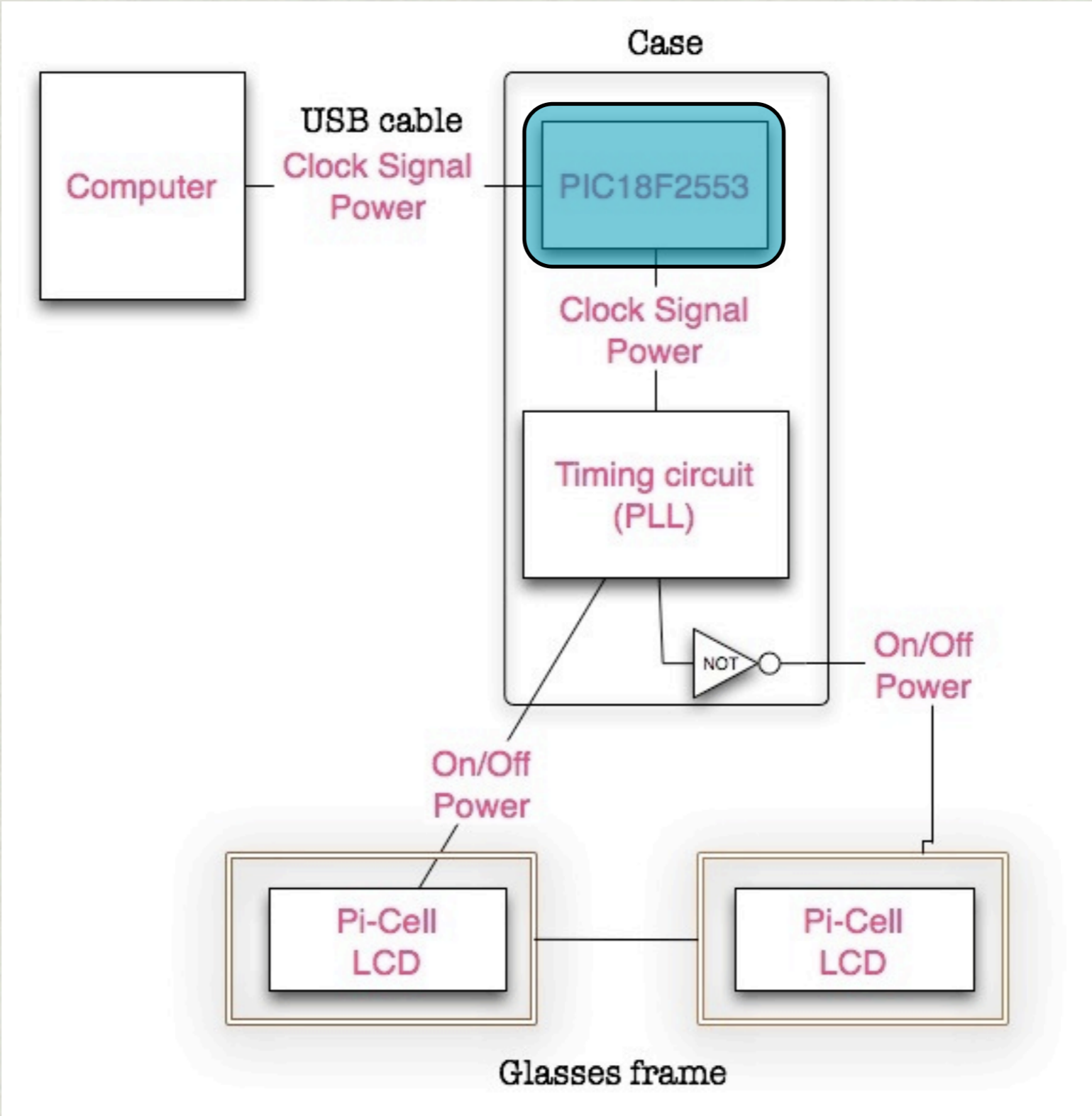

PIC Project Board

Pre-loaded PIC with firmware that makes the computer see the PIC USB interface as a COM port.

Software available to load new firmware to the PIC without a PIC programmer.

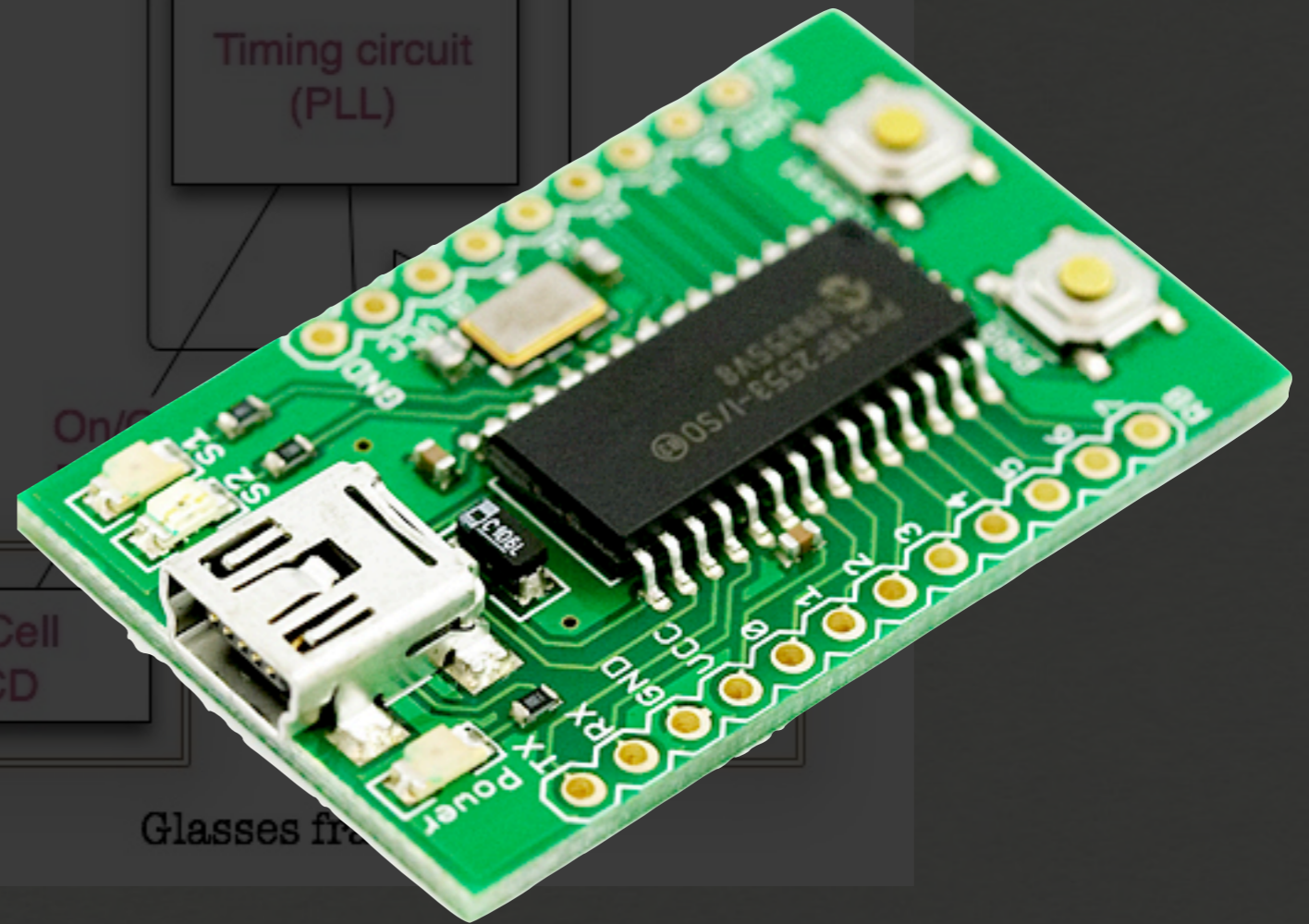

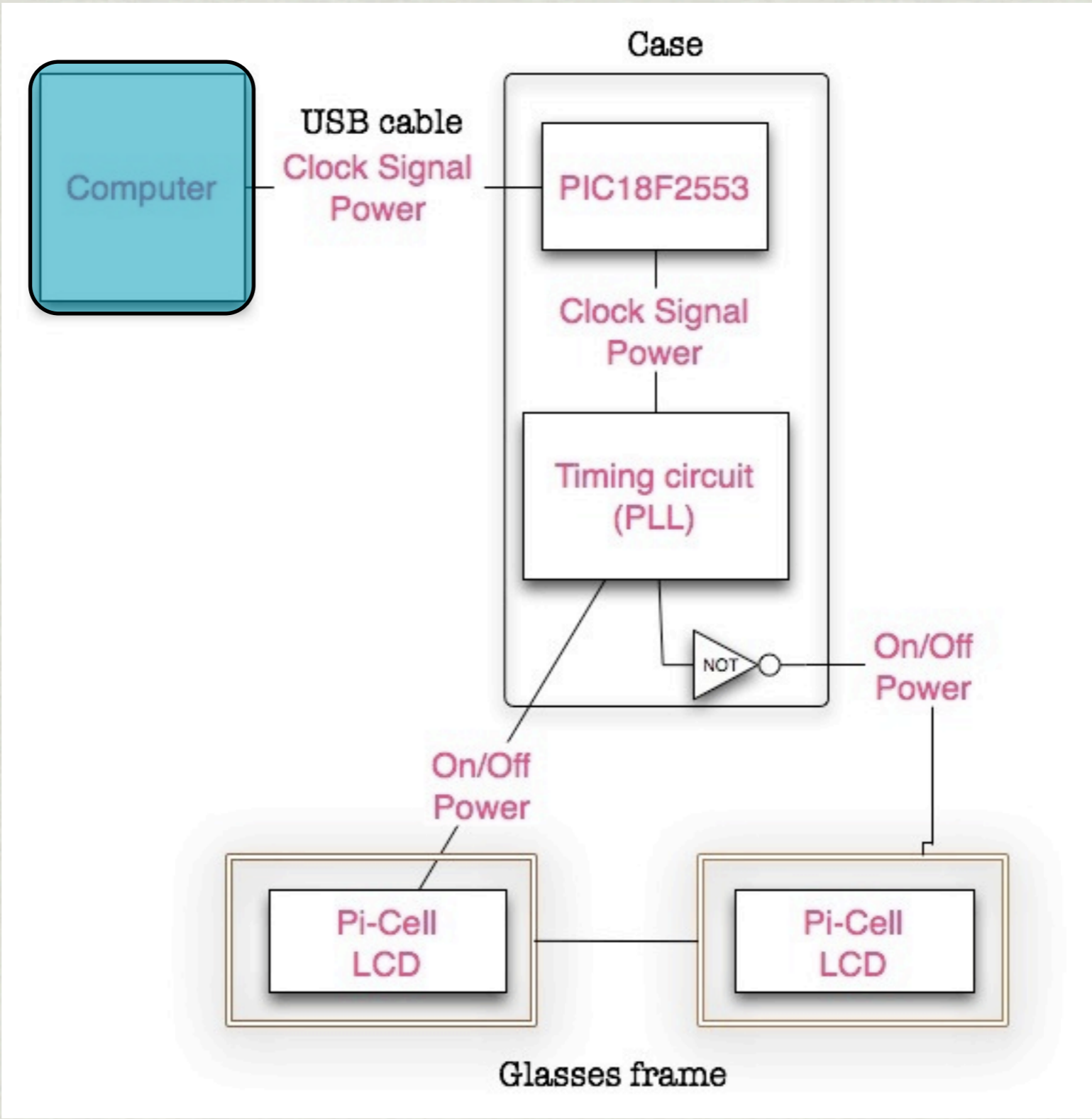

Double Camera Ray Tracer

Left and right cameras render two separate images and send them to OpenGL.

OpenGL sets the refresh rate. Our software communicates to USB to send synchronization signals to the glasses.

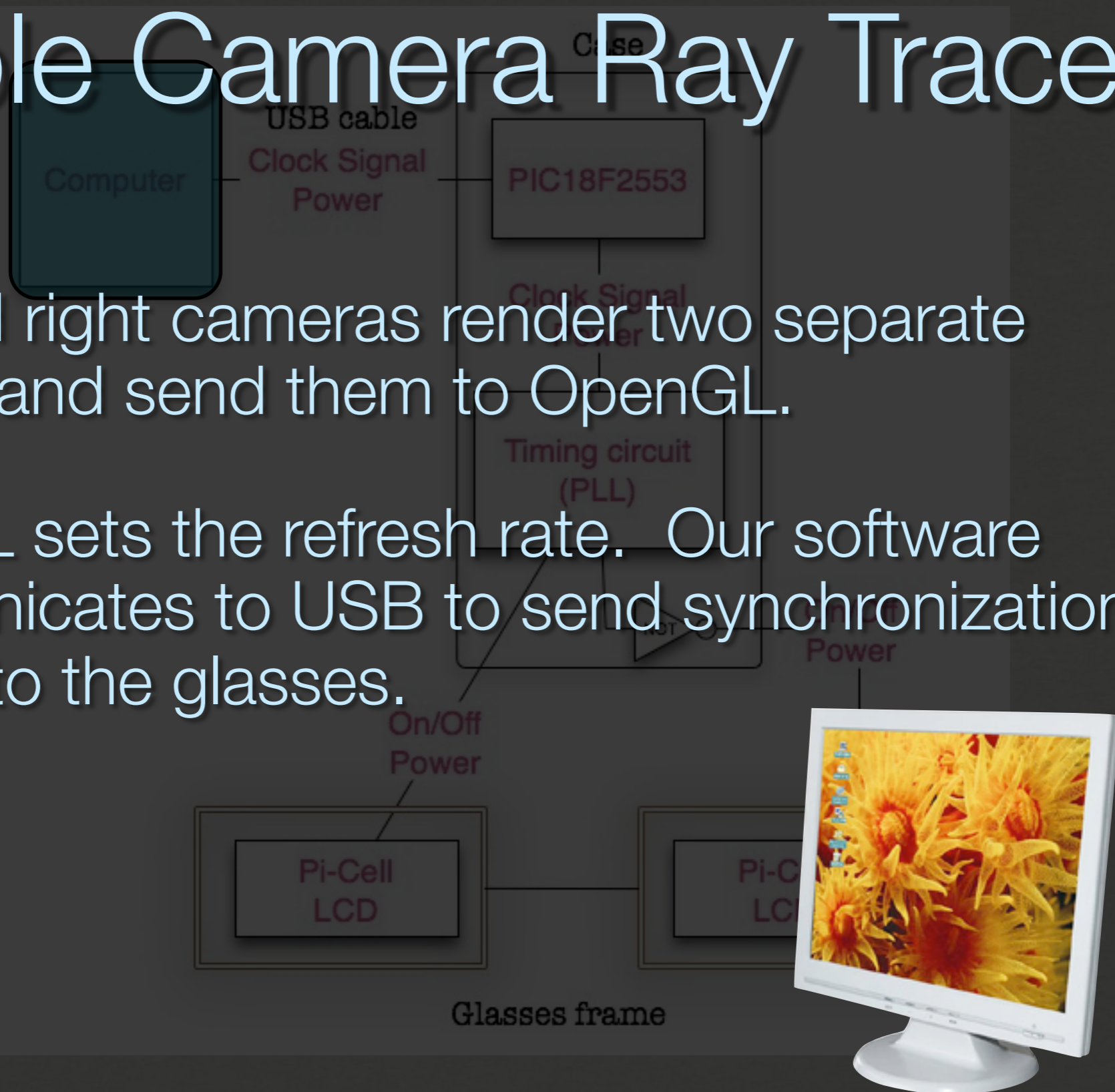

Demo

OpenGL allows us to set the resolution, the color depth, and the refresh rate of the monitor.

```
glutGameModeString("800x600:32@75");  
// enter full screen  
if (glutGameModeGet(GLUT_GAME_MODE_POSSIBLE))  
{  
    glutEnterGameMode();  
}
```

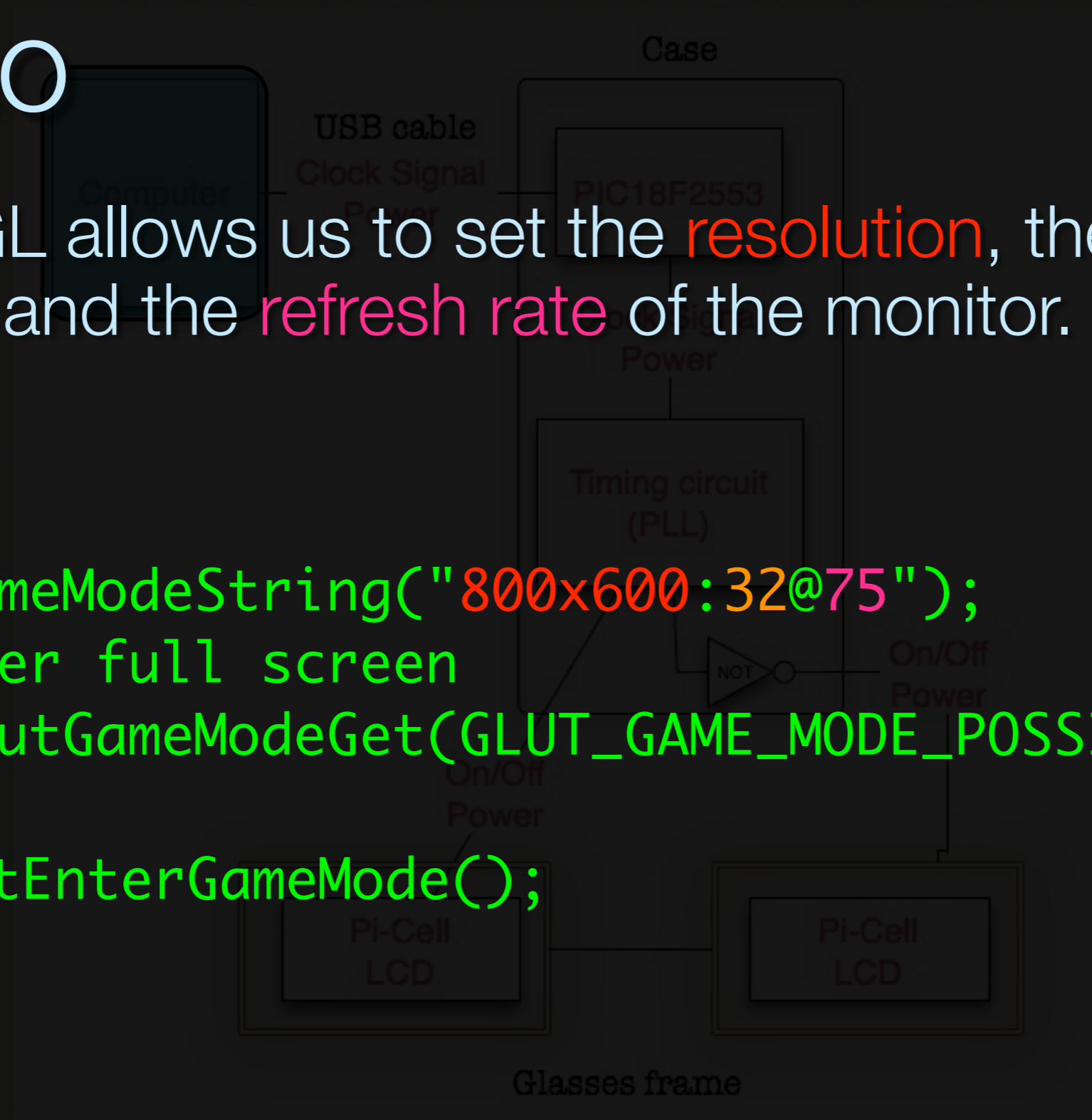

Demo

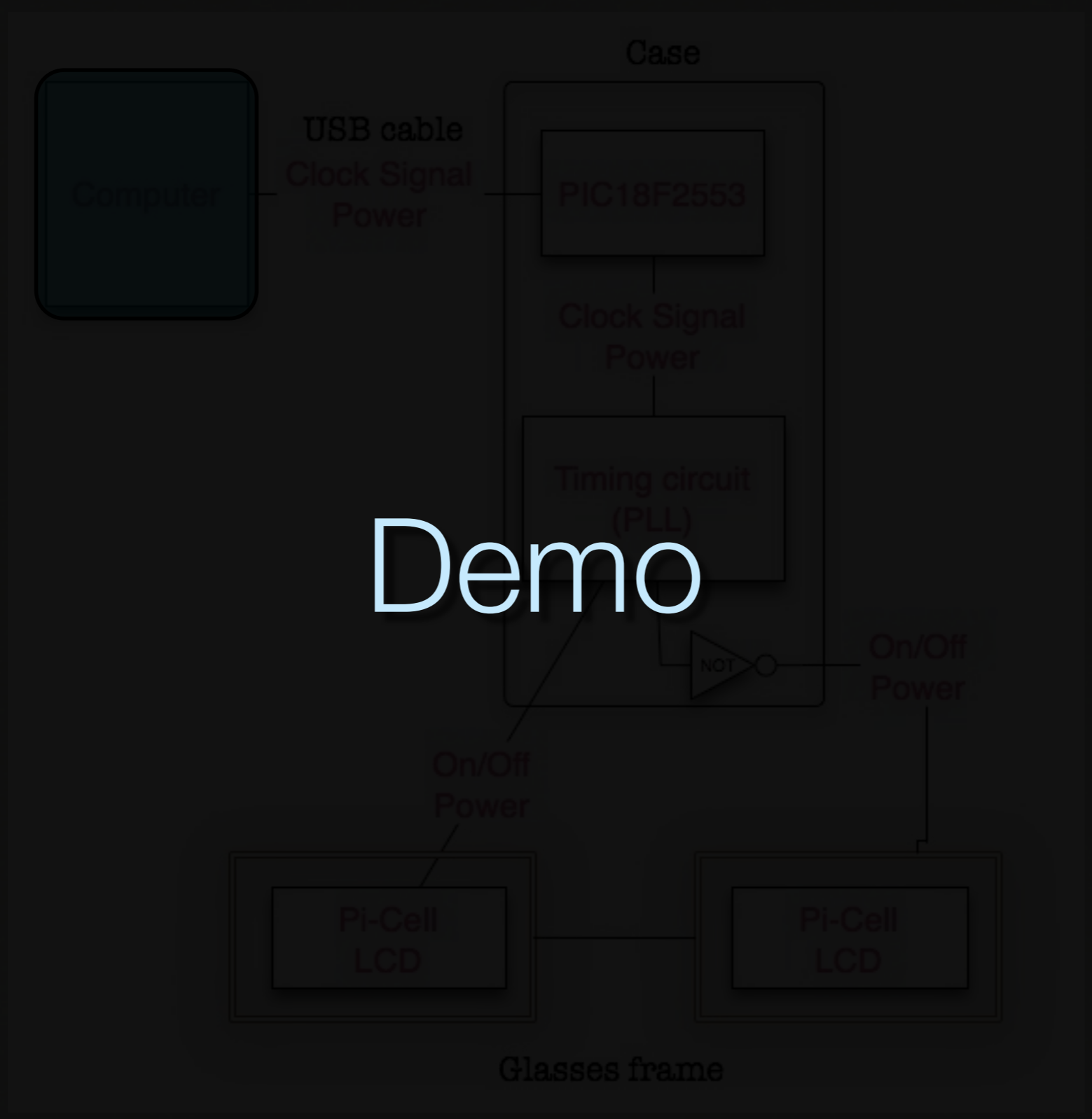

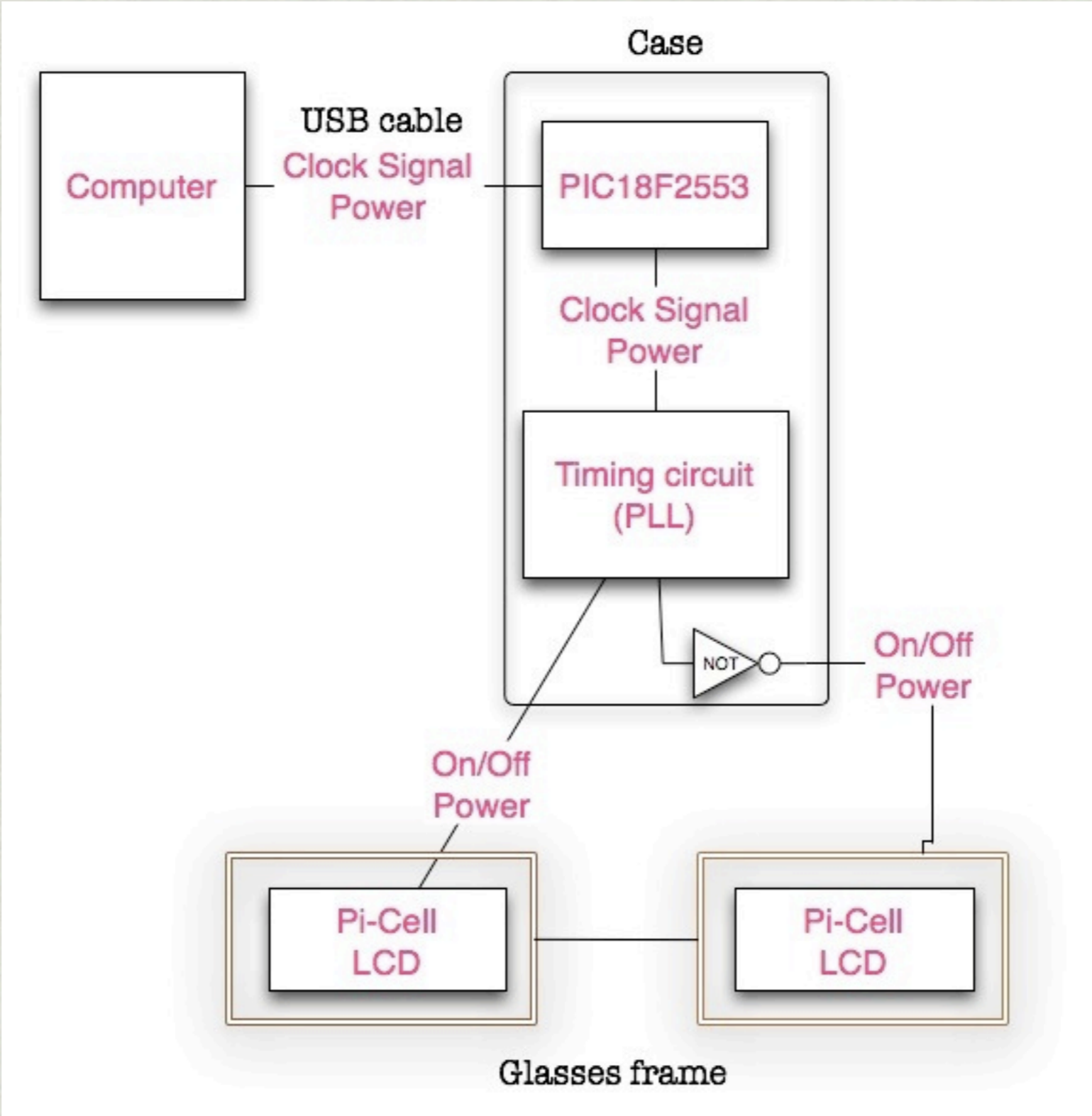

Software, USB, and Glasses

Interfaces

Computer - Software

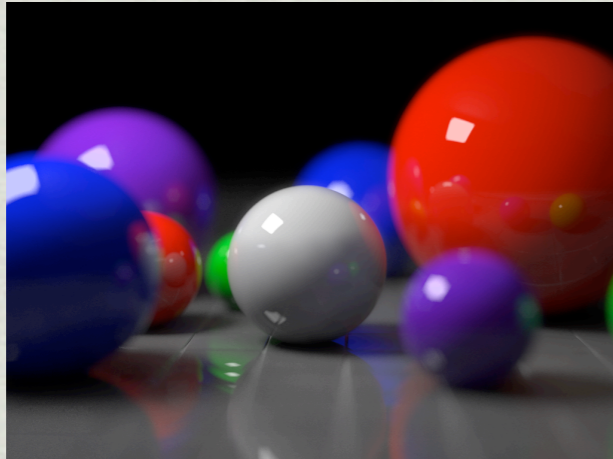

Double buffered ray
traced image complexity

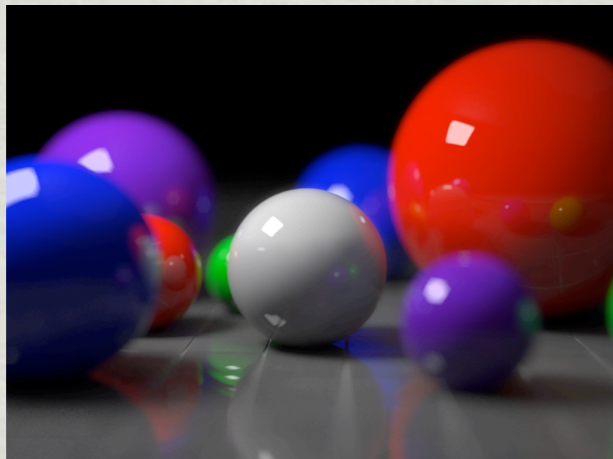

Stress
→



←
Specifications

Hardware Capabilities

Software - USB Driver

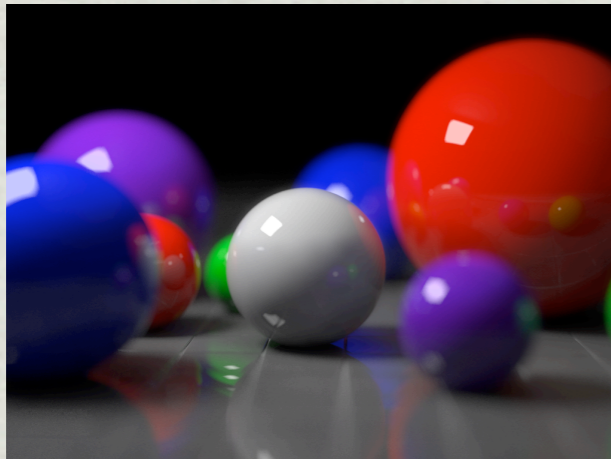

Double buffered stereo image

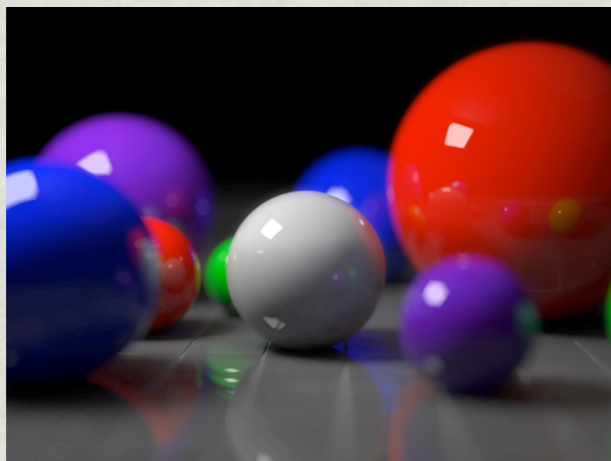

Timing
Information

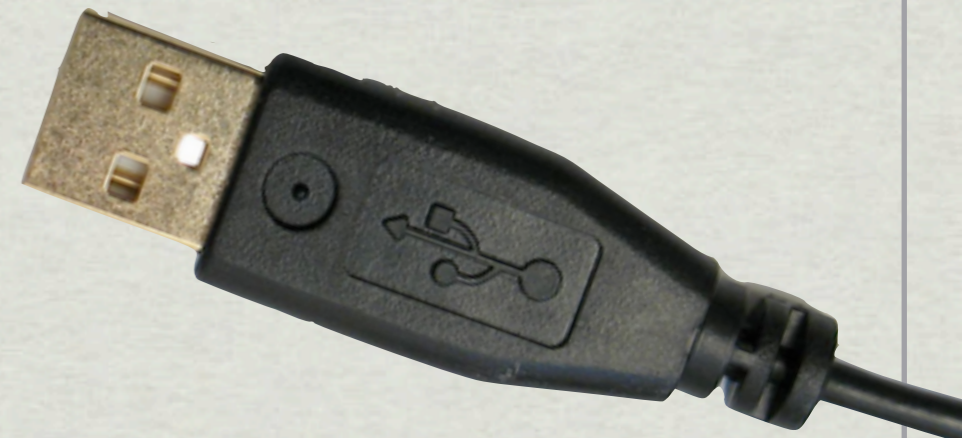

USB - Glasses



Standard A

- **D+** **D-** +

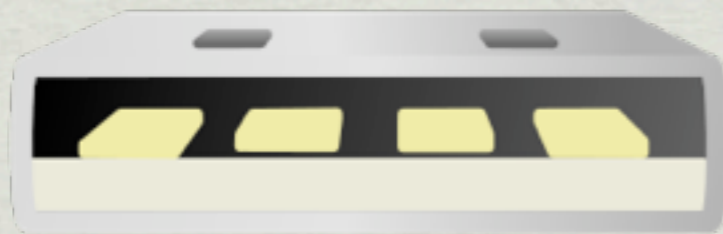

4 3 2 1

Half duplex differential signaling

Computer - Software

Hardware Capabilities

Response time

- Typically 3-6ms

LCD monitor required (no dealing with refresh rates and flicker)

Processor capabilities

- Typically 1.5-3Ghz, 1-2 cores

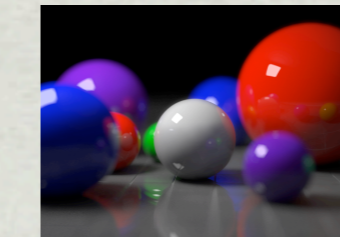

Double buffered ray traced image complexity

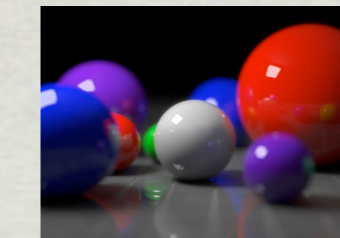

Hardware Capabilities

Adjust image accordingly

Find balance between several factors:

- Resolution
- Framerate
 - Manage using timer callback GLUT double buffer in OpenGL
- Ray branching
 - Reflection, refraction, and shadows
- Supported materials (Lambertian, dielectrics, volumes, etc)
- Supported objects (boxes, triangles, spheres, etc)

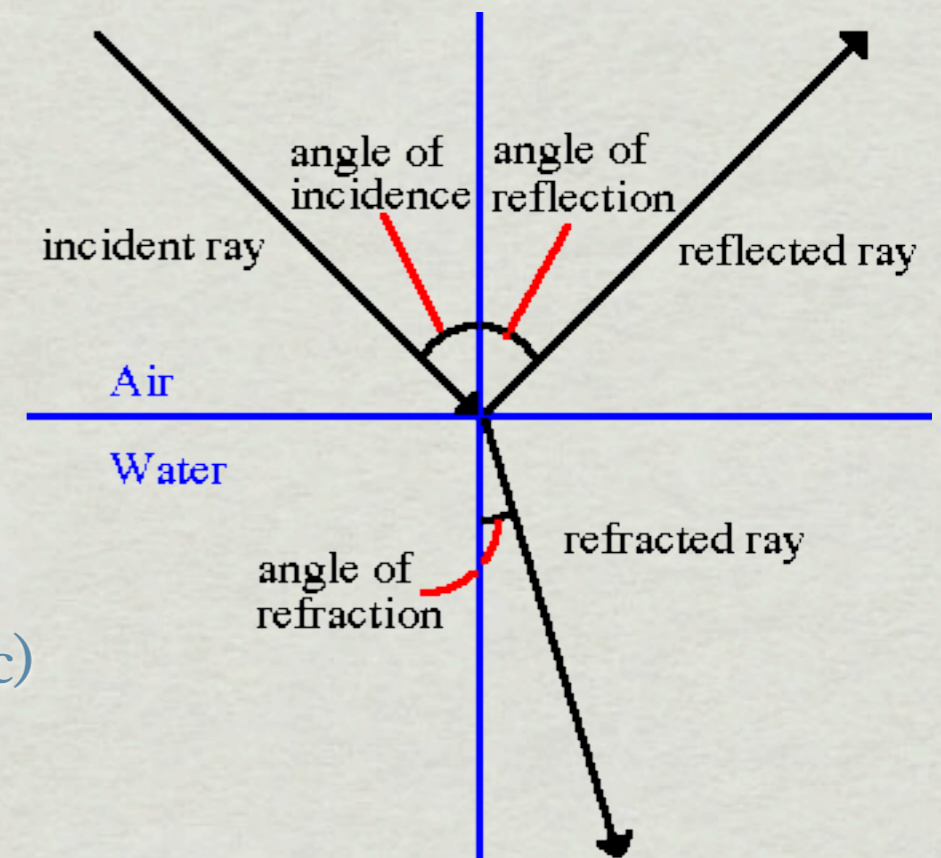

Software - USB Driver

Serial Driver Development in Windows

Support for the greatest common denominator

- 9 times more Windows OS installs than all others combined

Greater number of examples and tools

Implementation

USB module automatically mounts as COM port.

Opening, receiving, and sending communication via COM ports is simple.

USB module has a specified command set

- This can be used to save/load memory and access specific pins on the board.

Done directly in the program - no *separate* driver.

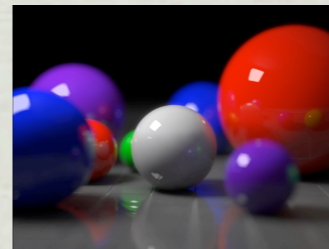

Double buffered stereo image

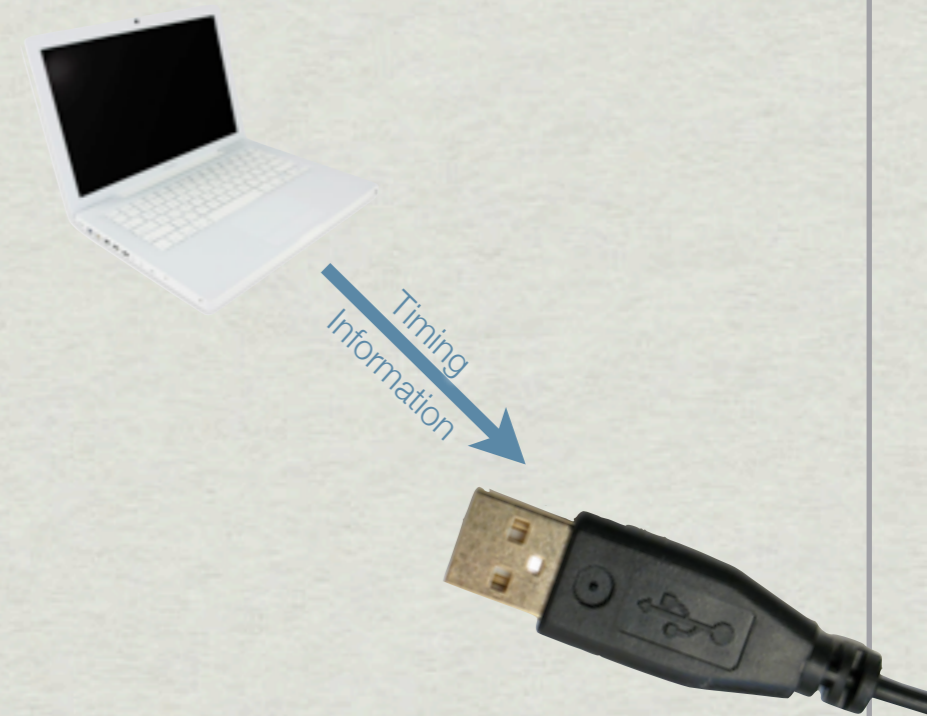
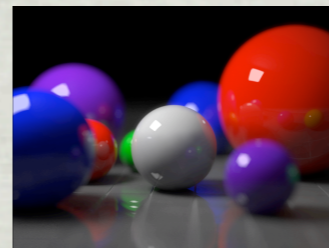

USB - Glasses

PIC18F2455 28 Pin USB Microcontroller

A fully featured package with the appropriate connections to receive USB and translate it back into a serial data signal.

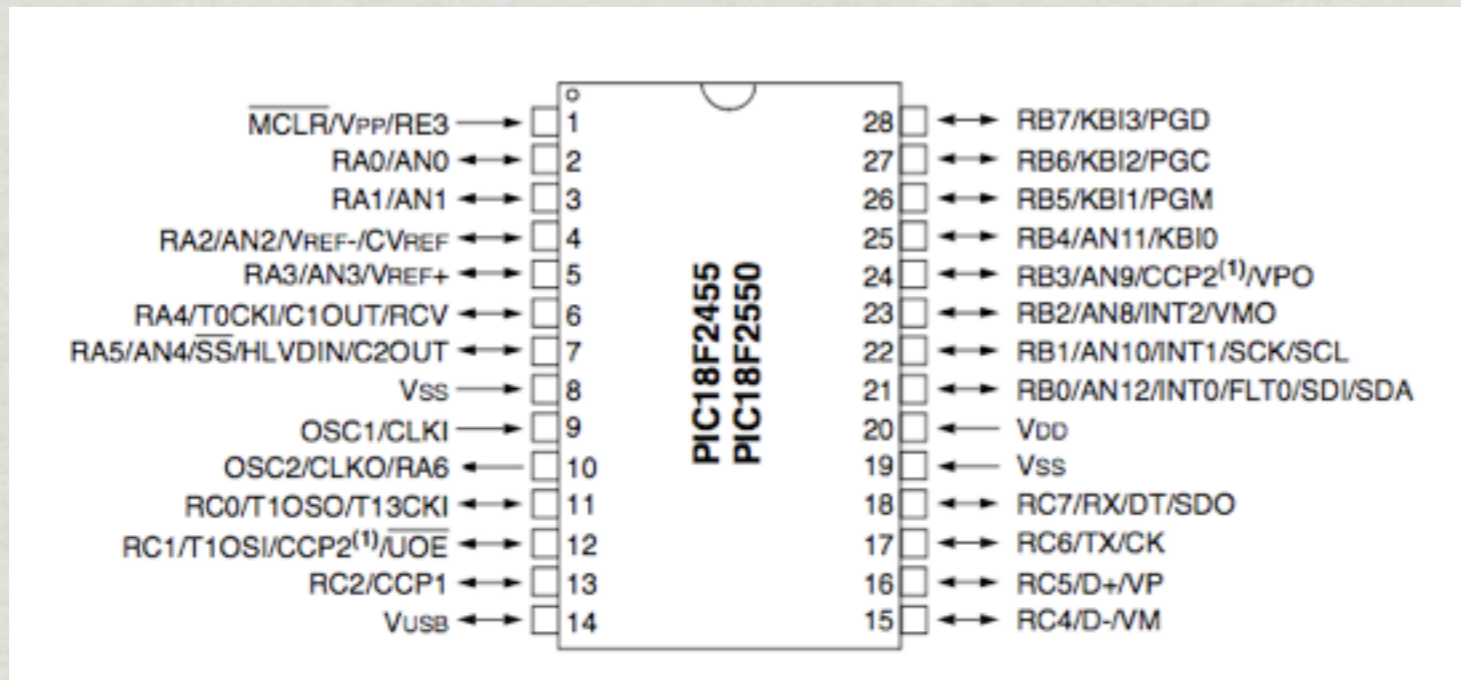

[HTTP://WW1.MICROCHIP.COM/DOWNLOADS/EN/DEVICE/DOC/39632D.PDF](http://ww1.microchip.com/downloads/en/devicedoc/39632d.pdf)

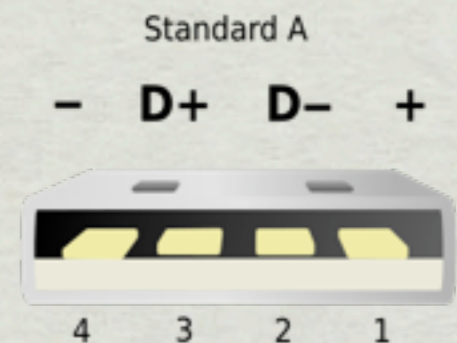

Information
Timing



USB - Glasses

PIC Project Board

Alleviates the need to write our own USB driver. Instead, we can send signals directly to a virtual COM port.

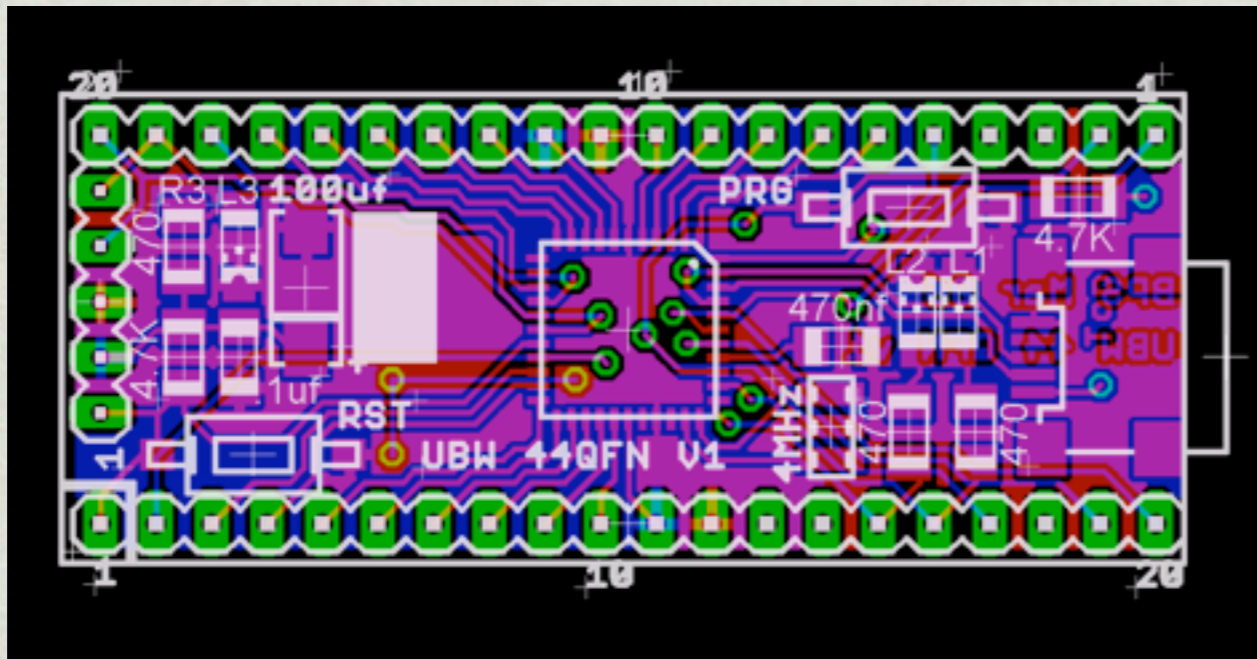

Information
Timing

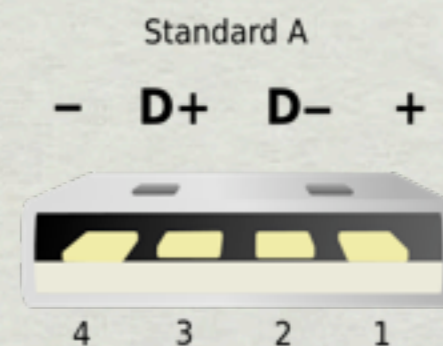

Schedule

Tasks	夏	9月				10月				11月				12月			
Glasses																	
Schematic Design & Verification	■																
Order and Test Parts	■																
Implementation from Schematic		■	■	■	■												
Build Frames						■	■										
Software																	
Implement Basic Ray Tracer	■																
Stereo Buffering		■	■	■	■												
Optimize for Speed												■	■	■	■		
Driver																	
COM Communication		■	■	■	■	■	■	■	■								
Hardware Software Integration										■	■	■	■	■	■		
Send sync data via USB										■	■	■	■				

Key: 夏 - Summer, 月 - Month

Bill of Materials

Item	Quantity	Unit Price	Description	Part Number	Vendor
Pi-cell LCD	4	\$15.00	LCD shutter lenses	50mm x 25mm size ones (no part number)	LiquidCrystal Technologies.com
PIC18F2455 USB Project Board	2	\$24.95	Translate USB signal back to direct serial.	PIC18F2455	Sparkfun www.sparkfun.com
USB cable	2	\$1.05	Taken from working USB mouse	N/A	University Surplus
Frames for glasses	2	\$5.00	Sunglasses sans lens	“No Boundaries Surf Rider Sunglasses”	Wal-mart (or beating up English majors if their glasses are more squarish)
Misc. Circuit Components	N/A	\$20.00	Misc. circuit components. RLC, Transistors, etc.	N/A	EE Stockroom, University

PRELIMINARY

Risks

Risks

- * Most of the major risks have been mitigated.
 - * USB is no longer a problem.
 - * Synchronization, while a risk, now seems very realistic.
- * William
 - * Might go insane after ten consecutive semesters of school.

完

END

